



# New Brunswick™ Galaxy® 170 R/170 S CO<sub>2</sub> Incubators

Operating manual

## **Copyright**

Copyright © 2014 Eppendorf AG, Germany. No part of this publication may be reproduced without the prior permission of the copyright owner.

The company reserves the right to change information in this document without notice. Updates to information in this document reflect our commitment to continuing product development and improvement.

## **Trademarks**

Eppendorf® and the Eppendorf logo are registered trademarks of Eppendorf AG, Germany.

New Brunswick™ and the New Brunswick™ logo are trademarks of Eppendorf AG, Germany.

Galaxy® is a registered trademark of Eppendorf, Inc., USA.

Microsoft® and Excel® are either registered trademarks or trademarks of Microsoft Corporation in the United States and/or other countries.

Trademarks are not marked in all cases with ™ or ® in this manual.

Eppendorf has attempted to identify the ownership of all trademarks from public records. Any omissions or errors are unintentional.

## Table of contents

<b>1</b>	<b>Operating instructions</b>	<b>7</b>
1.1	Using this manual	7
1.2	Danger symbols and danger levels	7
1.2.1	Hazard symbols	7
1.2.2	Degrees of danger	7
1.3	Symbols used	8
<b>2</b>	<b>Product description</b>	<b>9</b>
2.1	Main illustration	9
2.1.1	Galaxy 170 R/170 S CO <sub>2</sub> Incubators	9
2.2	Delivery package	12
2.2.1	Inspection of boxes	12
2.2.2	Packing list verification	13
2.3	Features	13
2.3.1	Control system	13
2.3.2	Direct heating system	13
2.3.3	Infrared sensor	13
2.3.4	Controlled humidity tray	13
2.3.5	Seamless chamber	14
2.3.6	Standard features	14
2.3.7	Multiple options	14
2.3.8	Two-level alarm system	14
2.4	Stacking devices	14
2.5	Optional equipment	15
<b>3</b>	<b>Safety</b>	<b>17</b>
3.1	Intended use	17
3.2	User profile	17
3.3	Application limits	17
3.3.1	Description of ATEX Guideline (94/9EC)	17
3.4	Information on product liability	18
3.5	Warnings for intended use	18
3.5.1	Personal injury and damage to device	18
<b>4</b>	<b>Installation</b>	<b>21</b>
4.1	Utilities requirements	21
4.2	Selecting the location	21
4.3	Unpacking the incubator	22
4.4	Initial setup	22
4.5	Making connections	26
<b>5</b>	<b>Operation</b>	<b>29</b>
5.1	Preparing for operation	29
5.2	Using the humidity tray	30
5.3	Operation for optional features	30
<b>6</b>	<b>Operating controls and function for Galaxy 170 R Incubator</b>	<b>31</b>
6.1	170 R control panel	31

**Table of contents**

Galaxy® 170 R/170 S CO<sub>2</sub> Incubators  
English (EN)

6.2	Programming	32
6.2.1	Temperature and CO <sub>2</sub> level	32
6.2.2	User access code	32
6.2.3	Removing user access code	32
6.3	Referencing the CO <sub>2</sub> sensor with Auto-Zero	33
6.4	USER settings	33
6.4.1	SET DATE AND TIME	34
6.4.2	AUDIBLE ALARM VOLUME ADJUST	34
6.4.3	PROGRAMMABLE CO <sub>2</sub> AUTOZERO	34
6.4.4	DATALOGGER	35
6.4.5	POWER FREQUENCY	35
6.4.6	DISABLE	35
6.4.7	DISINFECTION (optional)	35
6.5	DATALOGGER screen	36
6.5.1	ALARM EVENTS	36
6.5.2	TEMPERATURE GRAPH + DOOR OPEN BAR CHART	37
6.5.3	CO <sub>2</sub> GRAPH + DOOR OPEN BAR CHART	38
6.5.4	DIAGNOSTIC CHAMBER ELEMENT GRAPH	38
6.5.5	DIAGNOSTIC DOOR GRAPH	39
6.5.6	DIAGNOSTIC DOOR ELEMENT GRAPH	39
6.5.7	RESTART GRAPHIC RECORD	39
6.6	CHAMBER ALARMS menu screen	39
6.6.1	Chamber alarm system function	40
6.7	DIAGNOSTICS menu screen	41
6.8	HELP MENU screen	42
<b>7</b>	<b>Operating controls and function for Galaxy 170 S Incubator</b>	<b>43</b>
7.1	170 S control panel	43
7.2	Setting temperature and CO <sub>2</sub>	44
7.3	Programming the alarm system	44
7.3.1	Setting the high and low temperature alarms	44
7.3.2	Setting the CO <sub>2</sub> high and low alarms	45
7.3.3	Door open alarm	45
7.3.4	Alarm duration	45
7.3.5	Alarm arming delay	46
7.4	Chamber alarm system	46
7.4.1	Temperature sensor system alarms	47
7.4.2	Over-temperature cut-out and alarm	47
7.5	CO <sub>2</sub> Auto-zero system	47
7.5.1	Auto-zero	47
7.5.2	Changing auto-zero frequency	48
7.5.3	High temperature disinfection operation	49
<b>8</b>	<b>Maintenance</b>	<b>51</b>
8.1	Routine maintenance	51
8.1.1	General	51
8.1.2	Daily Checks	51
8.1.3	Weekly checks	51
8.1.4	Monthly checks	51
8.1.5	CO <sub>2</sub> Sampling with analyzer	52



8.1.6	Routine checks of the O <sub>2</sub> control option (170 R only) . . . . .	52
8.2	Service . . . . .	53
8.2.1	Fuse replacement . . . . .	53
8.3	Cleaning . . . . .	53
8.4	Disinfection/Decontamination . . . . .	53
8.5	High temperature disinfection . . . . .	55
<b>9</b>	<b>Transport, storage and disposal . . . . .</b>	<b>57</b>
9.1	Transport . . . . .	57
9.2	Storage . . . . .	57
9.3	Disposal . . . . .	57
<b>10</b>	<b>Technical data . . . . .</b>	<b>59</b>
10.1	Weight/dimensions . . . . .	59
10.1.1	Equipment dimensions . . . . .	59
10.1.2	Internal dimensions . . . . .	59
10.1.3	Transporting dimensions . . . . .	59
10.1.4	Shelves . . . . .	59
10.2	Power supply . . . . .	60
10.2.1	Mains/electrical supply . . . . .	60
10.3	Fuses . . . . .	60
10.4	Ambient conditions . . . . .	60
10.4.1	Temperature management . . . . .	60
10.4.2	CO <sub>2</sub> control . . . . .	61
10.4.3	Relative humidity . . . . .	61
10.4.4	Altitude limit . . . . .	61
10.4.5	Storage temperature . . . . .	61
10.4.6	Calibration . . . . .	61
<b>11</b>	<b>Ordering information . . . . .</b>	<b>63</b>
11.1	Accessories . . . . .	63
11.2	Available options . . . . .	64
<b>12</b>	<b>Equipment options . . . . .</b>	<b>65</b>
12.1	Cooling system . . . . .	65
12.1.1	Troubleshooting the cooling system . . . . .	66
12.2	BMS relay contact alarm . . . . .	66
12.3	High temperature disinfection . . . . .	68
12.3.1	Using the high temperature disinfection (Galaxy R) . . . . .	68
12.3.2	Using the high temperature disinfection (Galaxy S) . . . . .	70
12.3.3	High temperature disinfection option with oxygen control . . . . .	71
12.4	O <sub>2</sub> control (1 - 19 %) (Galaxy R only) . . . . .	72
12.4.1	Setting up the N <sub>2</sub> tank . . . . .	72
12.4.2	Setting up oxygen control . . . . .	72
12.4.3	Operating guidelines . . . . .	74
12.4.4	Referencing to atmosphere . . . . .	74
12.4.5	Replace sensor soon . . . . .	75
12.4.6	Replace sensor now . . . . .	75
12.4.7	Removing and replacing O <sub>2</sub> sensor . . . . .	76
12.4.8	Replacing the filter disc . . . . .	77

**Table of contents**

Galaxy® 170 R/170 S CO<sub>2</sub> Incubators  
English (EN)

12.4.9	Troubleshooting the O <sub>2</sub> sensor	78
12.4.10	Specifications	79
12.5	O <sub>2</sub> control (0.1 - 19 %) (Galaxy R only)	80
12.5.1	Setting up the N <sub>2</sub> tank	80
12.5.2	Setting up O <sub>2</sub> control	80
12.5.3	Enabling or disabling O <sub>2</sub> control	81
12.5.4	Alarms	81
12.5.5	Referencing to atmosphere	81
12.5.6	Programming desired O <sub>2</sub> level	82
12.5.7	Precautions	82
12.6	O <sub>2</sub> control (1 - 95 %) (Galaxy R only)	83
12.6.1	Setting up the N <sub>2</sub> tank	83
12.6.2	Setting up O <sub>2</sub> control	84
12.6.3	Enabling or disabling O <sub>2</sub> control	84
12.6.4	Important notes for O <sub>2</sub> levels > 80 %	85
12.6.5	Alarms	85
12.6.6	Referencing to atmosphere	85
12.6.7	Programming desired O <sub>2</sub> level	86
12.6.8	Other precautions	86
12.6.9	Specifications	86
12.7	O <sub>2</sub> Sensor replacement (Galaxy R only)	86
12.8	IP66 sealed electrical outlet socket	86
12.9	Humidity alert and monitoring package (Galaxy R only)	89
12.9.1	Humidity tray warning system	89
12.9.2	Humidity display and alarm system	90
12.10	Copper inner chamber	91
<b>13</b>	<b>Stacking stand installation</b>	<b>93</b>
13.1	Intended use	93
13.2	Warnings for intended use	93
13.3	General description	93
13.3.1	Ordering options	93
13.3.2	Stacking frame kit contents	94
13.4	Instructions for stacking incubators	94
13.5	Instructions for stacking a different model CO <sub>2</sub> incubator onto a Galaxy 170	102
<b>14</b>	<b>Declaration of conformity</b>	<b>105</b>
14.1	Declaration of conformity for 170 R	105
14.2	Declaration of conformity for 170 S	106
	<b>Index</b>	<b>107</b>









## 1 Operating instructions

### 1.1 Using this manual

- ▶ Carefully read this operating manual before using the device for the first time.
- ▶ Also observe the operating manual enclosed with the accessories.
- ▶ The operating manual should be considered as part of the product and stored in a location that is easily accessible.
- ▶ When passing the device on to third parties, be sure to include this operating manual.
- ▶ If this manual is lost, please request another one. The current version can be found on our website [www.eppendorf.com](http://www.eppendorf.com).

### 1.2 Danger symbols and danger levels

#### 1.2.1 Hazard symbols

	<b>Hazard point</b>		<b>Burns</b>
	<b>Electric shock</b>		<b>Material damage</b>
	<b>Explosion</b>		<b>Heavy loads</b>
	<b>Inhalation</b>		<b>Crush</b>

#### 1.2.2 Degrees of danger

The following degree levels are used in safety messages throughout this manual. Acquaint yourself with each item and the potential risk if you disregard the safety message.

<b>DANGER</b>	<i>Will</i> lead to severe injuries or death.
<b>WARNING</b>	<i>May</i> lead to severe injuries or death.
<b>CAUTION</b>	May lead to light to moderate injuries.
<b>NOTICE</b>	May lead to material damage.

**Operating instructions**

Galaxy® 170 R/170 S CO<sub>2</sub> Incubators  
English (EN)

### 1.3 Symbols used

Example	Meaning
▶	You are requested to perform an action.
1. 2.	Perform these actions in the sequence described.
•	List.
	References useful information.

## 2 Product description

### 2.1 Main illustration

#### 2.1.1 Galaxy 170 R/170 S CO<sub>2</sub> Incubators

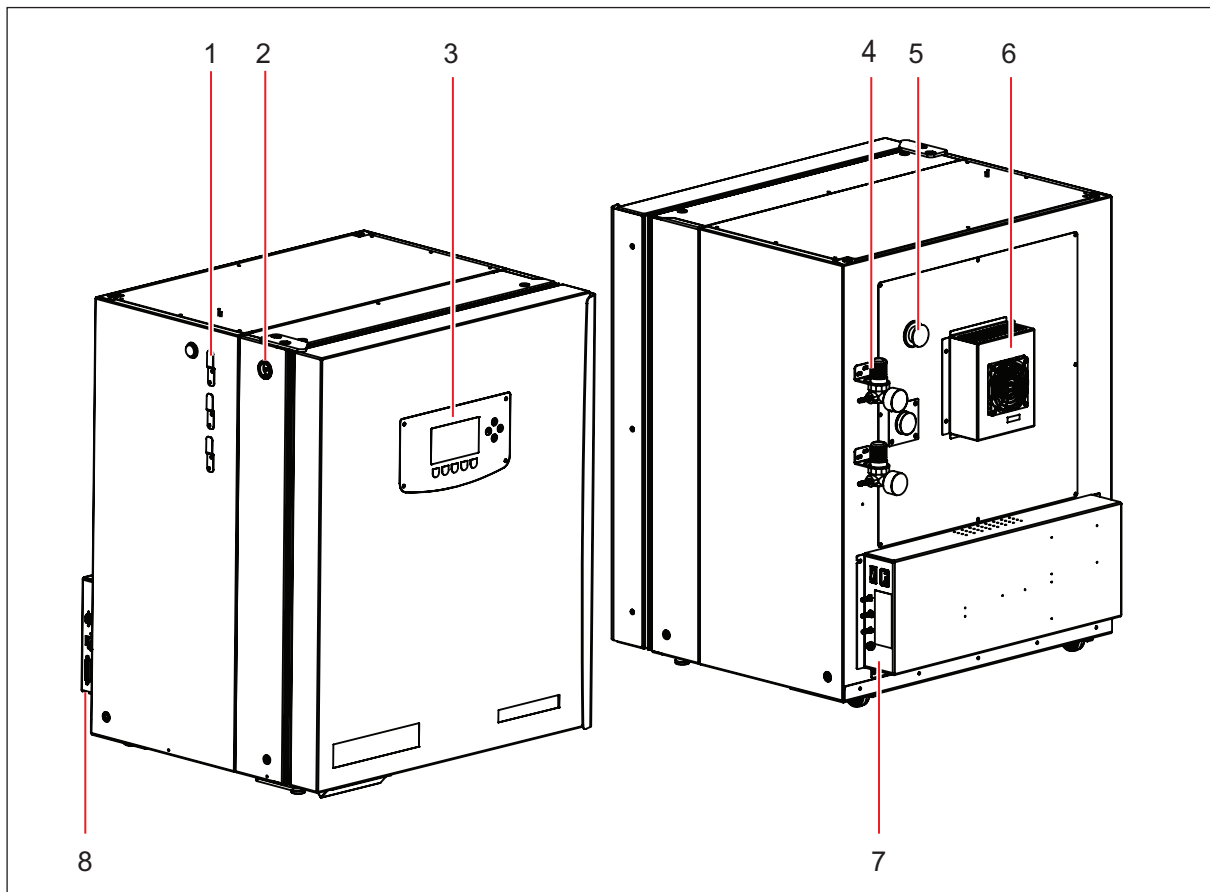

Fig. 2-1: Front and rear view of the 170 R/170 S CO<sub>2</sub> Incubators

- |   |  |
|---|--|
| 1 Sensor cover holder (present on older models) | 5 Access port                          |
| 2 CO <sub>2</sub> sample port                   | 6 Heat exchanger (cooling option only) |
| 3 Display/Interface (170 R display shown)       | 7 Left-hand side of control box        |
| 4 Inline regulator location (recommended)       | 8 Right-hand side of control box       |

**Product description**

Galaxy® 170 R/170 S CO<sub>2</sub> Incubators  
English (EN)

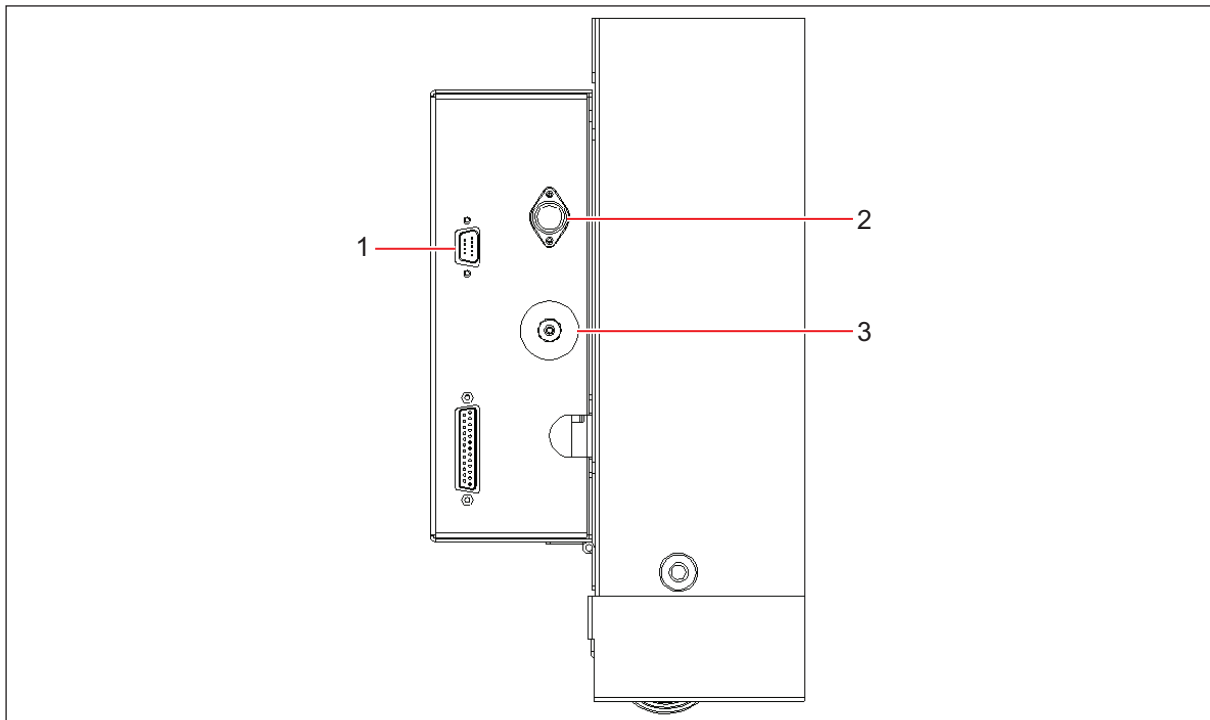

Fig. 2-2: Left-hand side control box

- 1 BMS relay contact alarm socket (Optional)**      **2 Auto-Zero filter**

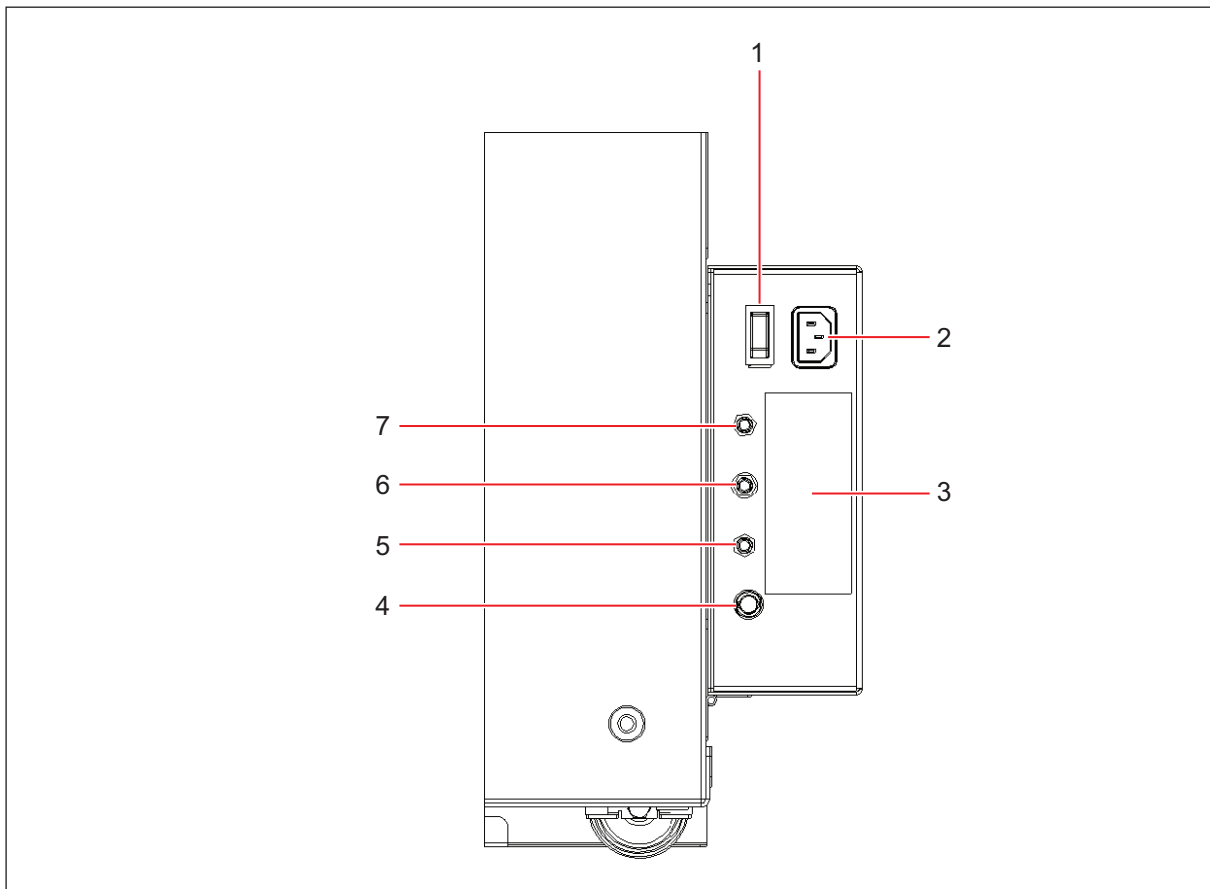

Fig. 2-3: Right-hand side control box

- |                               |   |
|-------------------------------|---|
| 1 On/Off switch               | 5 N <sub>2</sub> inlet (170 R optional only, option not available on 170 S) |
| 2 Mains/power cord receptacle | 6 CO <sub>2</sub> inlet   |
| 3 Label                       | 7 O <sub>2</sub> inlet (170 R optional only, option not available on 170 S) |
| 4 Fuse holder                 |   |

**Product description**

Galaxy® 170 R/170 S CO<sub>2</sub> Incubators  
English (EN)

## 2.2 Delivery package

Quantity	Description
1	<b>Operating manual</b>
4	<b>Non-tip perforated shelves</b> Installed
2	<b>Wired shelf racks</b> Installed
1	<b>Humidity tray</b> Installed
1	<b>White porous CO<sub>2</sub> sensor cover</b> Installed
2	Packed in accessories bag
1	<b>Black sensor cover</b> Installed
1	<b>Mains/power cord</b> Packed in box inside outer carton
1	<b>6 mm (~1/4 in) bore PVC hose, with large white filter</b> Packed in accessories bag
4	<b>Screw-in lifting handles</b> Packed in accessories bag
2	<b>Tubing clips</b> Packed in accessories bag
1	<b>Auto-zero CO<sub>2</sub> inlet filter</b> Installed
3	<b>Spare shelf rack foot</b> Packed in accessories bag
3	<b>Spare shelf rack spacer</b> Packed in accessories bag
2	<b>Silicone rubber suction feet</b> Packed in accessories bag (4 for 170 S)

### 2.2.1 Inspection of boxes

Inspect the boxes carefully for any damage that may have occurred during shipping. Report any damage to the carrier and to your local Eppendorf sales order department immediately.



## 2.2.2 Packing list verification

Unpack your order, saving the packing materials for possible future use. Save the operating manual for instruction and reference. Verify against your Eppendorf packing list that you have received the correct materials, and that nothing is missing. If any part of your order was damaged during shipping, is missing, or fails to operate, fill out the "Customer Feedback" form, available online at <http://newbrunswick.eppendorf.com/>.

## 2.3 Features

The Galaxy 170 R/170 S CO<sub>2</sub> Incubator is microprocessor-controlled and designed to ensure accurate and reliable operation.

### 2.3.1 Control system

The incubator incorporates a sophisticated control system that allows for easy programming, control and monitoring of the chamber conditions.

### 2.3.2 Direct heating system

A direct heating system, utilizing a thermal heating element, completely surrounds the incubator, providing an even temperature within the chamber. The independently and directly heated outer door is designed to ensure an even distribution of heat. This system ensures a rapid, controlled return to optimum chamber conditions after a door opening while also preventing any overshoot. The incubator's direct heat system provides for optimal use of laboratory space by allowing the most efficient internal volume for the footprint of the instrument.

### 2.3.3 Infrared sensor

A solid-state infrared sensor is used to control the level of CO<sub>2</sub>, providing excellent reliability, while remaining unaffected by humidity. The CO<sub>2</sub> system has a programmable automatic zero system (Auto-zero) to re-reference the sensor baseline to atmospheric CO<sub>2</sub> levels at regular intervals. A small pump supplies filtered atmospheric gas to the sensor. The chamber atmosphere within the sensor is completely displaced, allowing the control system to automatically reference the sensor, after which the pump is switched off, allowing the chamber atmosphere to homogenize back into the sensor. This provides for accurate CO<sub>2</sub> control without disturbing the chamber environment. For programming information (see *Temperature and CO<sub>2</sub> level* on p. 32). For Auto-Zero instructions (see *PROGRAMMABLE CO<sub>2</sub> AUTOZERO* on p. 34).

### 2.3.4 Controlled humidity tray

A controlled water tray at the bottom of the incubator allows a high, uniform relative humidity (RH) while preventing condensation in other parts of the chamber. Perforated shelves are provided as standard to facilitate a much faster recovery of RH conditions in the chamber than with unperforated shelves.

**Product description**Galaxy® 170 R/170 S CO<sub>2</sub> Incubators

English (EN)

### 2.3.5 Seamless chamber

The 170-liter chamber is seamless, to provide a sanitary and easy-to-clean environment, and all internal components are manufactured from polished stainless steel. The shelves (which are non-tip), shelf racks and humidity tray are easily removed without tools for thorough cleaning and are capable of being sterilized. Air circulation is achieved without the use of a fan, eliminating duct work (a potential source of contamination), simplifying cleaning, eliminating vibration, and facilitating use of microplates and low-volume culture.

### 2.3.6 Standard features

The Galaxy 170 R/170 S contain many standard features usually seen as options. It has a sealed inner glass door with a cam action lock to allow viewing of the cultures without compromising the internal atmosphere. This is also available as a split 4- or 8-inner-door option (to coordinate with shelves), which is ideal for critical hypoxic studies. In addition, there is a 25 mm (1 in) access port now standard to allow for seamless integration of independent probes or other equipment through the chamber.

### 2.3.7 Multiple options

The incubator features multiple options that can be installed to simplify maintenance and provide superior control over experimental conditions. For example, high-temperature disinfection quickly and conveniently disinfects the incubator's chamber at 120 °C, without the need to remove interior components or the CO<sub>2</sub> sensor. A humidity alert and monitoring package display relative humidity levels in the chamber on the display and warns the user before the humidity tray runs out of water, preventing dehydration of samples. Oxygen control provides for conditions that require above- or below-ambient oxygen levels. These and other options and accessories provide for a uniquely flexible CO<sub>2</sub> incubator capable of meeting the most demanding requirements. For details on equipment options (see *Equipment options on p. 65*).

### 2.3.8 Two-level alarm system

The incubator incorporates a two-level alarm system. The system alarms occur only if a problem develops with system components that require user intervention to rectify. The incubator also incorporates an over-temperature safety system that operates independently from the main control system.

## 2.4 Stacking devices

The incubator is designed so that one incubator can be safely stacked on top of either another Galaxy 170 R or a Galaxy 170 S using the optional stacking kit, which includes instructions. It is not possible to put any other type of incubator or heavy apparatus on top, as the top cover and stacking kit are designed to support only the feet of another Galaxy 170 incubator. For installation instructions (see *Stacking stand installation on p. 93*).

## 2.5 Optional equipment

The equipment options are factory-installed and model-dependent. A precise description of the equipment options can be found in this manual (see *Equipment options on p. 65*).

**Product description**

Galaxy® 170 R/170 S CO<sub>2</sub> Incubators  
English (EN)

## 3 Safety

### 3.1 Intended use

Eppendorf line of CO<sub>2</sub> Incubators are microprocessor-controlled instruments designed for cell culture. The direct-heated, fanless chambers are designed to provide high humidity levels, minimal vibration and precisely-regulated atmosphere of temperature and gas(es) required for cell growth in T-flasks, microplates, and other cultureware. They are intended for indoor laboratory use, only.



#### **CAUTION! Lack of safety due to incorrect accessories or spare parts**

Accessories and spare parts that are not recommended by Eppendorf compromise the safety, function and precision of the device. Eppendorf cannot be held liable or accept any liability for damage resulting from the use of non-recommended accessories and spare parts.

- ▶ Only use accessories and original spare parts recommended by Eppendorf.
- 

### 3.2 User profile

The device may only be operated by trained lab personnel who have carefully read this operating manual and are familiar with the device functions.

### 3.3 Application limits

#### 3.3.1 Description of ATEX Guideline (94/9EC)



#### **DANGER! Explosion hazard**

- ▶ Do not operate the device in areas where work is completed with explosive substances.
  - ▶ Do not use this device to process any explosive or highly reactive substances.
  - ▶ Do not use this device to process any substances which could create an explosive atmosphere.
- 

Due to its design and the ambient conditions in its interior, the device is not suitable for use in potentially explosive atmospheres.

The device may only be used in a safe environment, e.g., the open atmosphere of a ventilated lab.

The use of substances which may contribute to a potentially explosive atmosphere is not permitted.

The final decision regarding the risks associated with using these types of substances is the user's responsibility.

**Safety**

Galaxy® 170 R/170 S CO<sub>2</sub> Incubators  
English (EN)

### 3.4 Information on product liability

In the following cases, the designated protection of the device may be compromised.

The liability for the function of the device passes to the operator if:

- The device is not used in accordance with this operating manual.
- The device is used outside of the range of application described in the succeeding chapters.
- The device is used with accessories or consumables that were not approved by Eppendorf.
- Service or maintenance is completed on the device by people who are not authorized by Eppendorf.
- The owner has made unauthorized modifications to the device.

### 3.5 Warnings for intended use

Before using the device, read the operating manual and observe the following general safety instructions.

#### 3.5.1 Personal injury and damage to device

**WARNING! Risk of personal injury**

- ▶ Elevated levels of CO<sub>2</sub> may be found in and around the operating area of the CO<sub>2</sub> incubator.
- ▶ Wear personal protective equipment (PPE).

**WARNING! Risk of personal injury**

Burns due to hot surface.

- ▶ Do not touch the equipment during the high temperature disinfection cycle.
- ▶ Do not open equipment door during the cycle.

**CAUTION! Risk of personal injury**

- ▶ At least four people are required to safely lift the incubator.

**NOTICE! Risk of material damage**

- ▶ Never try to lift the incubator by its door; this would cause permanent damage to the incubator.

**NOTICE! Risk of material damage**

- ▶ To avoid possible damage to the CO<sub>2</sub> sensor, never leave water in the humidity tray while the incubator is switched off, or when a high temperature disinfection cycle is initiated (optional feature).
- ▶ Allow a clearance of 50 mm (2 in) to allow access for oxygen sensor (if installed) removal.



**NOTICE! Risk of material damage**

- ▶ CO<sub>2</sub> gas pressure must not exceed 5 PSI (0.35 bar).



**NOTICE! Risk of material damage**

Working with electrical power inside a humid environment (where the incubator is humidified) can cause damage. The following precautions should be observed:

- ▶ The instrument or equipment, and its external connections, to be used inside the chamber should be specified as suitable for use in a humid environment, and at 37 °C (see also “Using Powered Equipment within the Chamber”). If in doubt, consult with the manufacturer of the equipment.
  - ▶ Always ensure the connections are properly and securely made.
  - ▶ Be sure to switch OFF the green illuminated switch on the front left of the incubator before connecting or disconnecting equipment inside the chamber, if equipped with optional IP66 socket.
  - ▶ The Sealing Cap must always be in place when the socket is not in use.
  - ▶ Both the incubator and the IP66 enclosure must be plugged into an electrical supply protected by an RCD device. Any device chosen must be a self-resetting type which will automatically reconnect power to the incubator as soon as power is restored following a power failure.
-

**Safety**

Galaxy® 170 R/170 S CO<sub>2</sub> Incubators  
English (EN)



## 4 Installation

### 4.1 Utilities requirements

The following utilities requirements are needed for operation:

Utility	Requirement
Electricity	120 V, 50/60 Hz earthed/grounded mains/electrical supply with minimum capacity of 10 amps
	230 V, 50/60 Hz earthed/grounded mains/electrical supply with minimum capacity of 8 amps
CO <sub>2</sub> gas	Cylinder with 100 % CO <sub>2</sub> vapor withdrawal, together with a two-stage regulator for pressure control to 18.85 PSI (1.3 bar)



CO<sub>2</sub> gas pressure must not exceed 5 PSI (0.35 bar). It is recommended that a in-line pressure regulator be used for each gas type introduced into the incubator to precisely control gas pressure (see *Accessories on p. 63*).

### 4.2 Selecting the location

Select a level surface capable of withstanding the operating weight of the incubator. Actual operating weight will be dependent on both the options installed, and the material stored in the incubator.

The incubator is designed to operate at a chamber temperature of 4.0 °C above ambient, and at an absolute minimum ambient temperature of 15 °C if the incubator is being operated at 37 °C. **Maximum allowable ambient temperature is 28 °C.**



Position incubator to allow clearance for opening door and access to the CO<sub>2</sub> sample port located on the left side of the incubator.

Avoid placing the incubator in areas that may affect performance, such as those listed below.

**DO NOT** place the incubator:

- Directly under, beside or within the air flow of heating or air-conditioning ducts, or other drafts;
- Directly beside heat-generating equipment such as a heater, an autoclave or an oven;
- Near the exhaust of heat- or cold-generating equipment;
- Near a window exposed to direct sunlight;
- Directly on top of any heat-generating apparatus;
- Without minimum ventilation clearance of 10 mm (0.5 in) all around (50 mm (2 in) in back if you have the cooling system option).

**Installation**

Galaxy® 170 R/170 S CO<sub>2</sub> Incubators  
English (EN)

### 4.3 Unpacking the incubator



**CAUTION! Risk of personal injury**

- ▶ At least four people are required to safely lift the incubator.



**NOTICE! Risk of material damage**

- ▶ Never try to lift the incubator by its door; this would cause permanent damage to the incubator.

1. Install the four lifting handles into the tapped holes on both sides of the incubator.

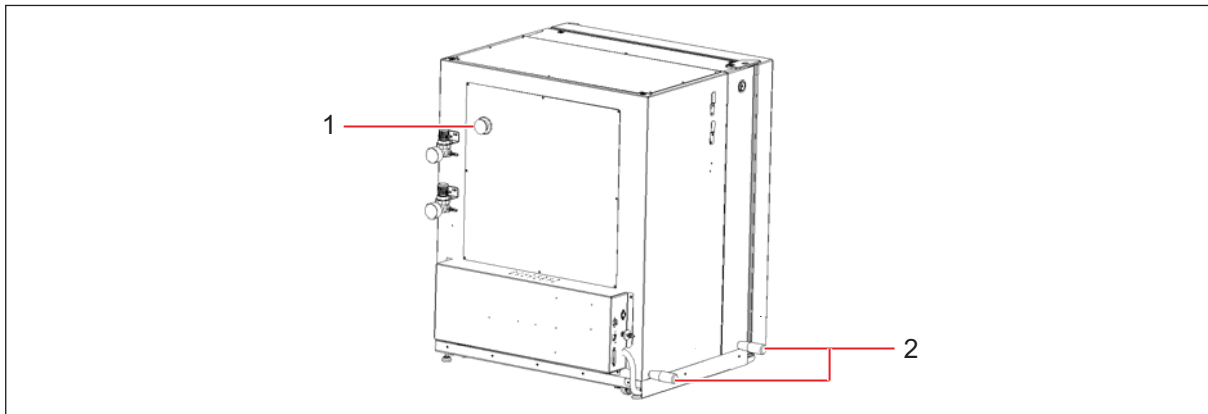

Fig. 4-1: Installing lifting handles

**1 Access port**

**2 Lifting handles**

2. Carefully move the incubator to its operational location using lifting handles. Silicone rubber suction feet are supplied for non-slip application.
3. Remove all internal packaging.
4. Remove the four lifting handles from the incubator and store for future use.

### 4.4 Initial setup

1. Place the silicone rubber suction feet onto the incubator's adjustable feet.



Keep silicone rubber suction feet installed at all times.

2. Place two rubber shelf rack feet, and one shelf rack spacer onto each shelf rack (see Fig. 4-2 on p. 23).
3. Place the two shelf racks inside the chamber. Ensure that the cushioned tubing spacers are snug against the side walls; these spacers allow clearance for the shelves.

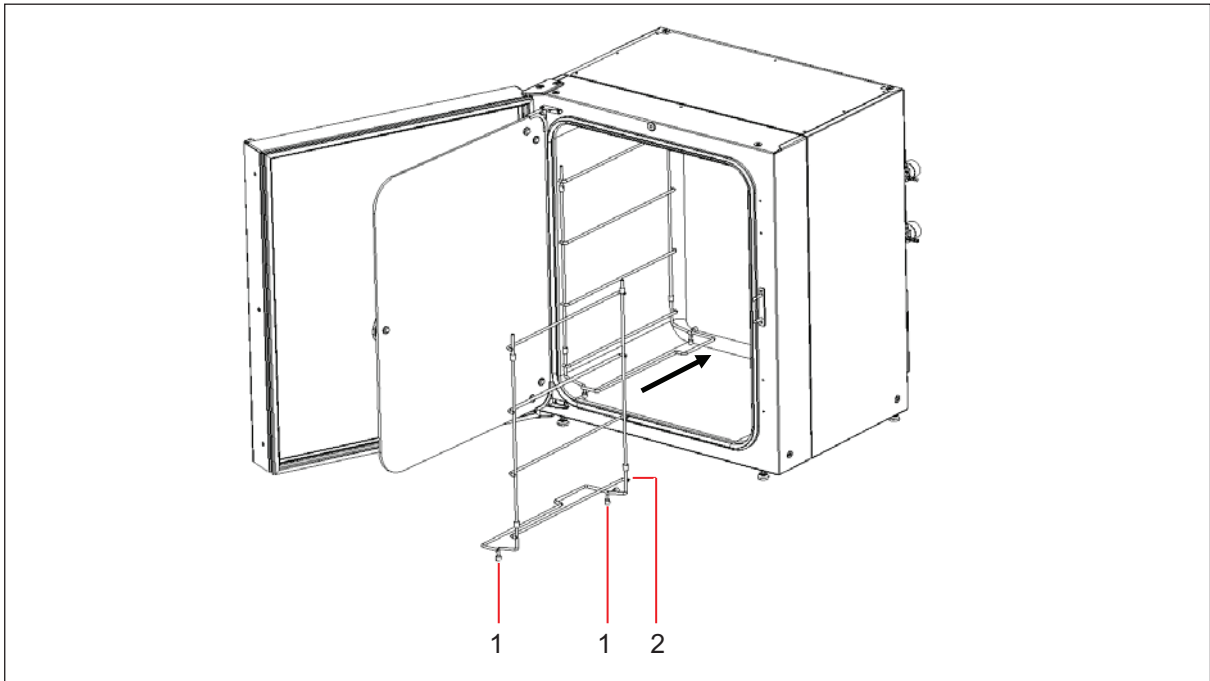

Fig. 4-2: Inserting shelf racks

**1 Shelf rack feet**

**2 Shelf rack spacer**



Only shelf racks for four shelves are shown in this manual. Shelf racks for eight shelves are also available.

4. Install the tie rod at the back of the shelves to hold both sides together.

**Installation**

Galaxy® 170 R/170 S CO<sub>2</sub> Incubators  
English (EN)

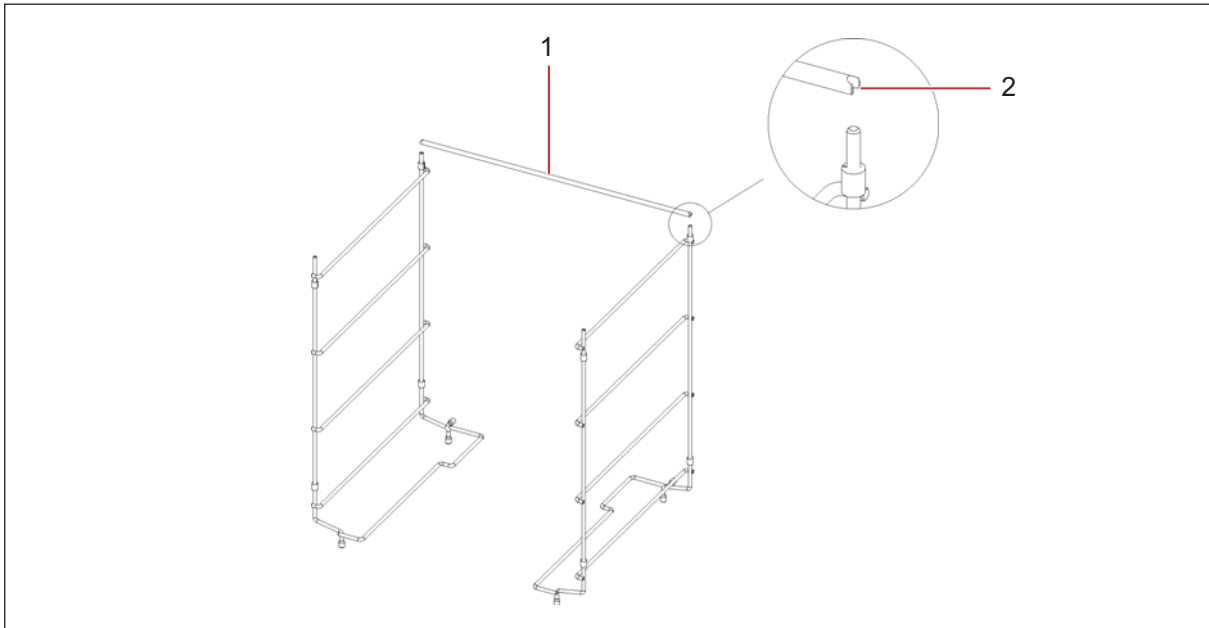

Fig. 4-3: Installing tie bar to shelf racks

**1 Tie rod****2 Tie rod anti-tip groove**

5. Install the shelves, top to bottom. Ensure that each shelf's anti-tip groove is properly inserted (faced upward and to the rear of the incubator) onto each of the shelf rack guides.

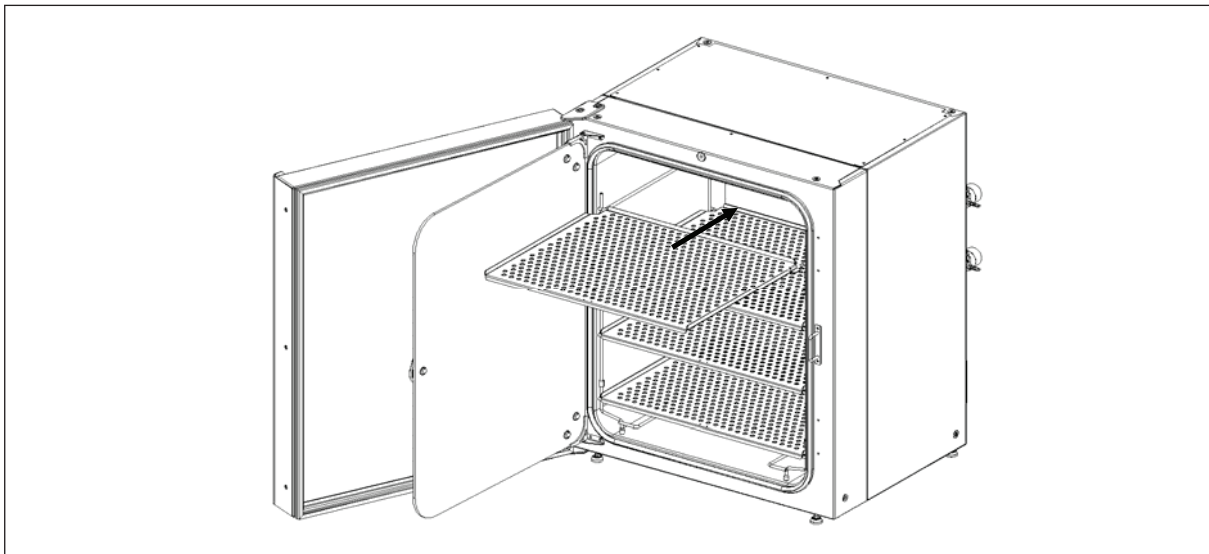

Fig. 4-4: Inserting shelves

6. Level the incubator by adjusting the feet. Place a small level on the second shelf of the incubator. Adjust the leveling feet until the incubator is level and stable. Lock the leveling feet in place by tightening the locking nuts on each foot.
7. Slide the humidity tray onto the lowest shelf rack support.

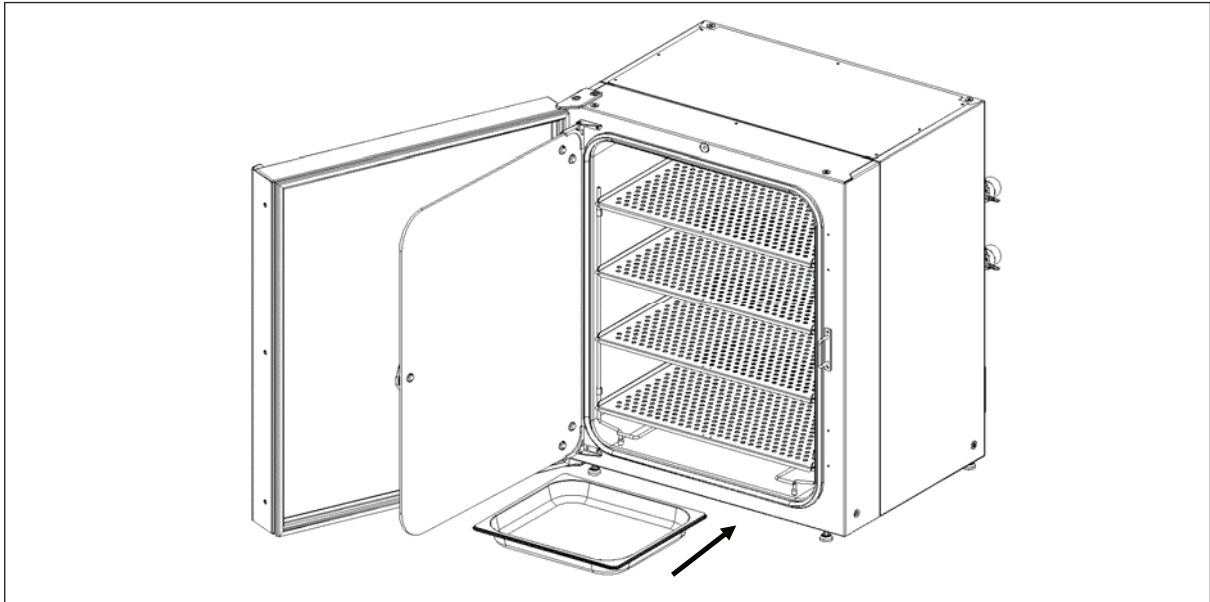

Fig. 4-5: Installing the humidity tray

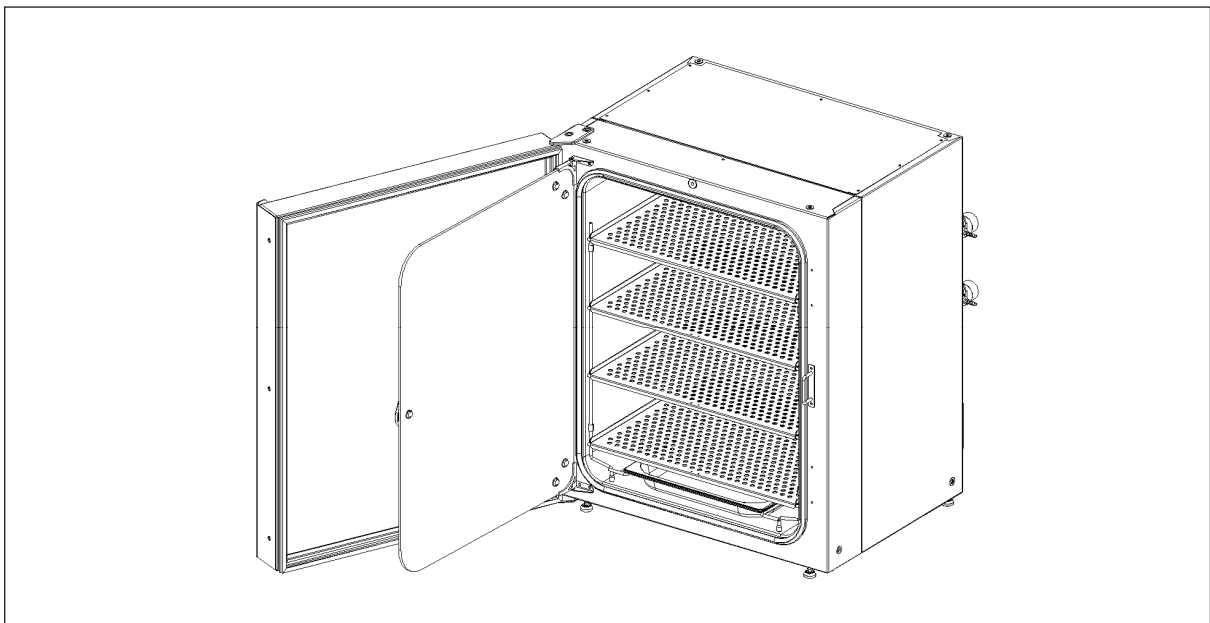

Fig. 4-6: Humidity tray installed

**Installation**

Galaxy® 170 R/170 S CO<sub>2</sub> Incubators  
English (EN)

## 4.5 Making connections

---

**WARNING! Risk of personal injury**

- ▶ Elevated levels of CO<sub>2</sub> may be found in and around the operating area of the CO<sub>2</sub> incubator.
- ▶ Wear personal protective equipment (PPE).

**WARNING! Danger due to incorrect power supply**

- ▶ Only connect the device to voltage sources that meet the requirements on the name plate.
  - ▶ Only use sockets with a protective earth (PE) conductor and suitable power cable.
- 

1. Remove sensor (CO<sub>2</sub>, O<sub>2</sub>, and RH) protective cover (option dependant), and store for future use.
2. Remove gas inlet connector protection cap.

3. Attach supplied 6 mm bore PVC hose with large white filter to gas inlet connector.

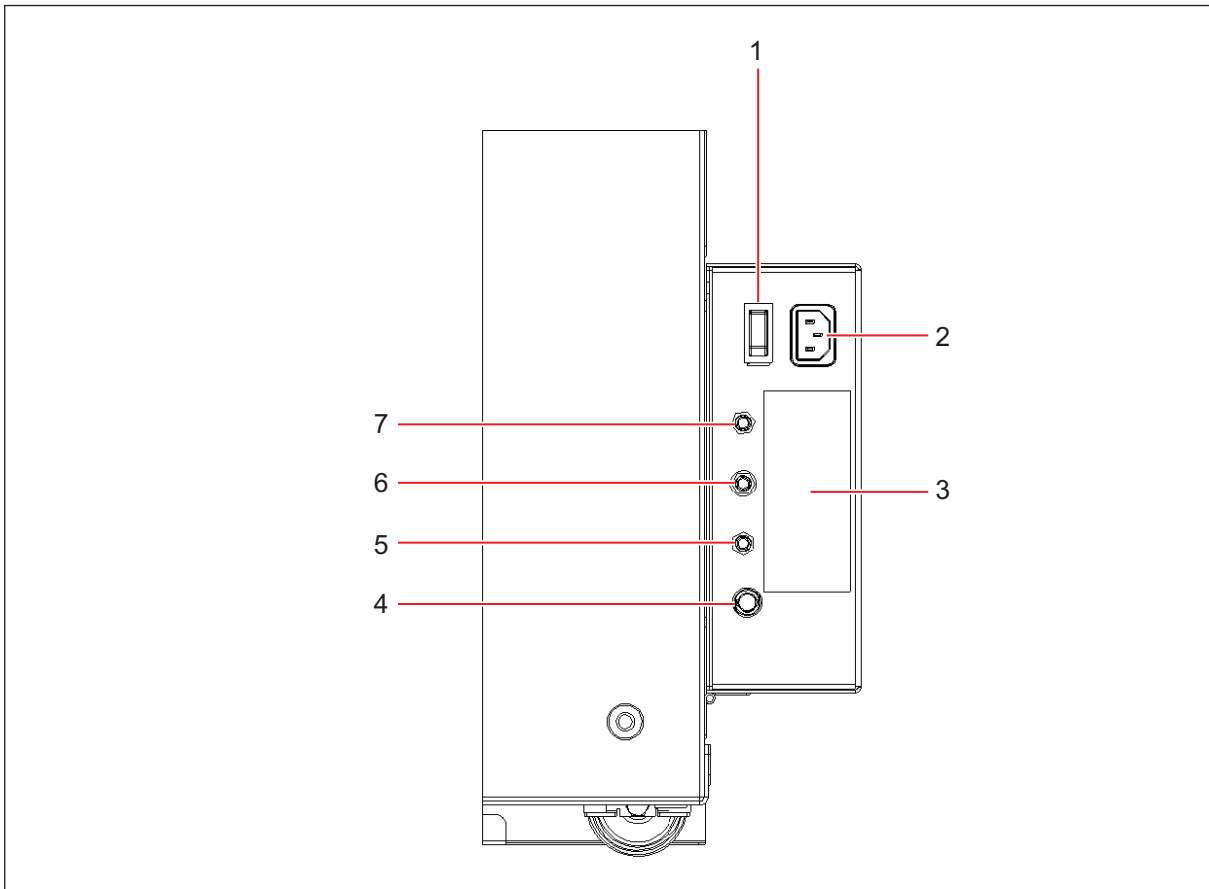

Fig. 4-7: Making connections

- |                                      |   |
|--------------------------------------|---|
| <b>1 On/Off switch</b>               | <b>5 N<sub>2</sub> inlet (170 R optional only, option not available on 170 S)</b> |
| <b>2 Mains/power cord receptacle</b> | <b>6 CO<sub>2</sub> inlet</b>   |
| <b>3 Label</b>                       | <b>7 O<sub>2</sub> inlet (170 R optional only, option not available on 170 S)</b> |
| <b>4 Fuse holder</b>                 |   |

4. Attach recommended optional in-line pressure regulator (not supplied), if applicable. For connection location (see Fig. 2-1 on p. 9).

**Installation**

Galaxy® 170 R/170 S CO<sub>2</sub> Incubators  
English (EN)



Attaching in-line pressure regulator, (not supplied), is a recommended option.



Fig. 4-8: In-line pressure regulator

- The in-line pressure regulator controls Secondary Gas Pressure. A default pressure setting of 5 PSI (0.35 bar) is recommended.
  - A large size cylinder of "CO<sub>2</sub> - Vapour Withdrawal" is required to supply the incubator. This cylinder controls Primary Gas Pressure. Fitting a Two-Stage CO<sub>2</sub> Pressure Regulator is recommended.
  - Ensure the protective cover(s) are removed from all sensor(s) and replaced in the holder for safekeeping. Be very careful, as you remove the black CO<sub>2</sub> sensor cover, not to accidentally remove the white porous sensor cover. This must remain in place.
5. Secure tubing using the supplied hose clips.
    - The inlet filter may already be installed on the equipment tray in a filter housing, if supplied loose (packed in accessories bag) the part needs to be installed before use.
  6. Attach CO<sub>2</sub> inlet filter to Auto-Zero connection, located on side of the equipment box.
  7. Confirm voltage requirements.
    - Cross reference incubator label information on side of equipment box.
  8. Using mains/power cord supplied, connect incubator to correct mains/voltage supply.
  9. Turn incubator **On**.



## 5 Operation

### 5.1 Preparing for operation

1. Remove the black protective cover from the CO<sub>2</sub> sensor, taking care not to remove the white porous cover; store the black cover on the sensor cover holder on the side of the incubator. The sensor cap should be placed back on the sensor when the incubator is to be cleaned.

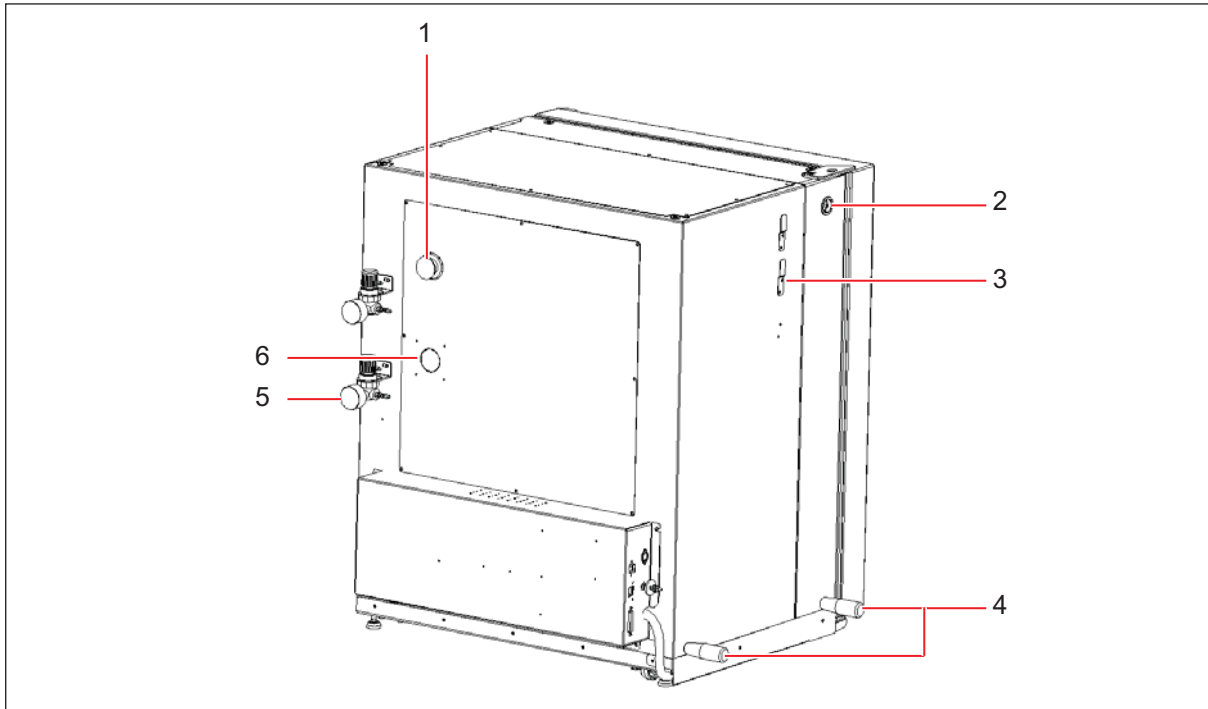

Fig. 5-1: CO<sub>2</sub> Incubator rear view

- |                                     |   |
|-------------------------------------|---|
| <b>1 Access port</b>                | <b>4 Removable lifting handles</b>                      |
| <b>2 CO<sub>2</sub> sample port</b> | <b>5 Location for mounting in-line regulators</b>       |
| <b>3 Sensor cover holder</b>        | <b>6 O<sub>2</sub> sensor location (not shown here)</b> |

2. Ensure that the white porous sensor cover remains in place.
3. Using the mains/power cord provided, connect the incubator to a earthed/grounded mains/power supply.
4. Switch the incubator ON using the on/off switch at the rear of the cabinet.  
The display will illuminate immediately.
5. Turn on the CO<sub>2</sub> gas supply with the pressure regulator set to 5 PSI (0.35 bar).
6. The chamber setpoints are pre-programmed at 37.0 °C and 5 % CO<sub>2</sub>. Leave the incubator on until the programmed chamber temperature and CO<sub>2</sub> concentration have been reached.

**Operation**

Galaxy® 170 R/170 S CO<sub>2</sub> Incubators  
English (EN)



- The incubator's CO<sub>2</sub> valve is disabled until the incubator reaches the temperature setpoint. After the temperature setpoint is reached, the CO<sub>2</sub> valve is activated, allowing the incubator to reach the CO<sub>2</sub> setpoint.
- If power is interrupted to the incubator long enough for the temperature to drop below setpoint, the CO<sub>2</sub> valve will be deactivated until temperature setpoint is again achieved. (This serves to avoid spurious CO<sub>2</sub> readings while the incubator is below its temperature setpoint)

7. Leave the incubator running for at least two hours (preferably overnight) to allow conditions to stabilize.

## 5.2 Using the humidity tray



### NOTICE! Risk of material damage

- ▶ To avoid possible damage to the CO<sub>2</sub> sensor, never leave water in the humidity tray while the incubator is switched off, or when a high temperature disinfection cycle is initiated (optional feature).
- ▶ Allow a clearance of 50 mm (2 in) to allow access for oxygen sensor (if installed) removal.



- The humidity tray should be left in place at all times.
- Use distilled water only in the humidity tray. Use of any other types of water including deionized water will cause corrosion inside the incubator.

If humidification is required:

1. Fill the humidity tray with 1.5 - 2.5 liters of warm (37.0 °C) distilled water.
2. *For cell culture work*, we recommend adding copper sulphate in the humidity tray. Tests have shown that, in addition to inhibiting bacterial growth in the tray, this can reduce contamination on the chamber walls. Add one small teaspoonful (~0.5 g) of copper sulphate to the water in the humidity tray.
3. *For sensitive work*, we do not recommend the use of any biocide in the humidity tray. To reduce the possibility of contamination, every 10 to 14 days, empty the tray, clean it with a solution of 70 % isopropyl alcohol and 30 % distilled water, and then refill it with 1.5 liters of warm distilled water.



The humidity level within the chamber is not adjustable. The internal chamber will reach ~95 % relative humidity at 37 °C using the 1.5-liter humidity tray.

## 5.3 Operation for optional features

For functionality on optional features (see *Available options on p. 64*).

## 6 Operating controls and function for Galaxy 170 R Incubator

### 6.1 170 R control panel

The control panel consists of an LCD display, five function keys and four direction keys.

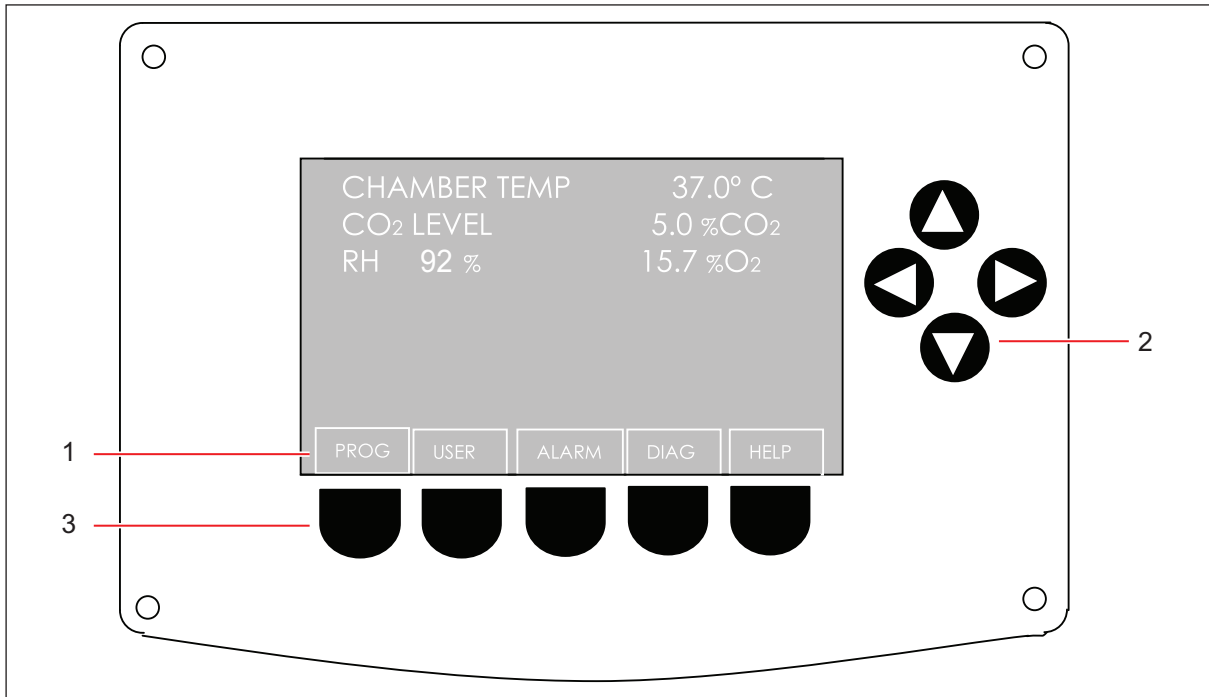

Fig. 6-1: Galaxy 170 R control panel (normal operation)

#### 1 Function key menu

Displays the current available screen functions

#### 2 Directional keys

The four Directional Keys will move the cursor around the screen and adjust values

#### 3 Function keys

The purpose of each Function Key is identified at the bottom of the display, above the corresponding key; the function may change from screen to screen



The **HELP** file contains most of the information in this operating manual, together with more detailed troubleshooting information.

## Operating controls and function for Galaxy 170 R Incubator

Galaxy® 170 R/170 S CO<sub>2</sub> Incubators

English (EN)

## 6.2 Programming

### 6.2.1 Temperature and CO<sub>2</sub> level

Perform the following steps to set the desired operating temperature and CO<sub>2</sub> level. For more information on this feature (see *Infrared sensor on p. 13*).

1. Press the **PROG** function key.
2. In the **PROG** screen that appears, press the desired function key, **TEMP** or **CO<sub>2</sub>**, then use the ◀ and ▶ direction keys to adjust the value.



If the incubator is supplied with the option of oxygen control, the setpoint for the oxygen level can be selected and changed like the temperature and CO<sub>2</sub> setpoints.

3. When the desired setpoint is displayed, press the **ENTER** function key.
4. After making adjustments (if any were made), allow the incubator to stabilize at the setpoints before continuing.



If the chamber temperature goes above the temperature setpoint by 1 °C, the over-temperature system will activate.

### 6.2.2 User access code

Programmable user access code allows you to restrict access to the **PROG**, **USER**, and **ALARM** screens (where settings can be changed) to authorized persons only.

To set the User Access Code (if required):

1. In the **PROG** screen (accessed by pressing the **PROG** function key).  
The user access code will be displayed as a series of four asterisks.
2. Use the left and right direction keys to move to each code position, and the up and down direction keys to select a number from 0 to 9.
3. Once the number is selected, press the **ENTER** function key to save the code.
4. After returning to the main screen, programming access will require the code to make any further programming changes.



Take care to note your password somewhere. If a password is forgotten, you must contact a customer service representative to recover or delete the forgotten password.

### 6.2.3 Removing user access code

1. In the **PROG** screen, enter the current access code.
2. Now program **0000** as the new access code.
3. Press the **ENTER** function key to save the change.  
The code is now cancelled and programming is no longer restricted.



If the access code has been misplaced, you will be unable to make changes to your incubator's settings. Contact customer service or your service representative for instructions on how to regain access to your incubator.

### 6.3 Referencing the CO<sub>2</sub> sensor with Auto-Zero

Prior to using the incubator, you should manually perform a CO<sub>2</sub> Auto-Zero (see *PROGRAMMABLE CO<sub>2</sub> AUTOZERO* on p. 34):

1. Perform a CO<sub>2</sub> Auto-Zero by pressing the USER function key (see *PROGRAMMABLE CO<sub>2</sub> AUTOZERO* on p. 34), selecting the **PROGRAMMABLE CO<sub>2</sub> AUTOZERO**, and pressing the **START** key.
2. The incubator will display a countdown as the Auto-Zero is running.
3. When the countdown is complete, the incubator is ready to use.

### 6.4 USER settings

In the **USER** screen, you can adjust the features called out on the screen.

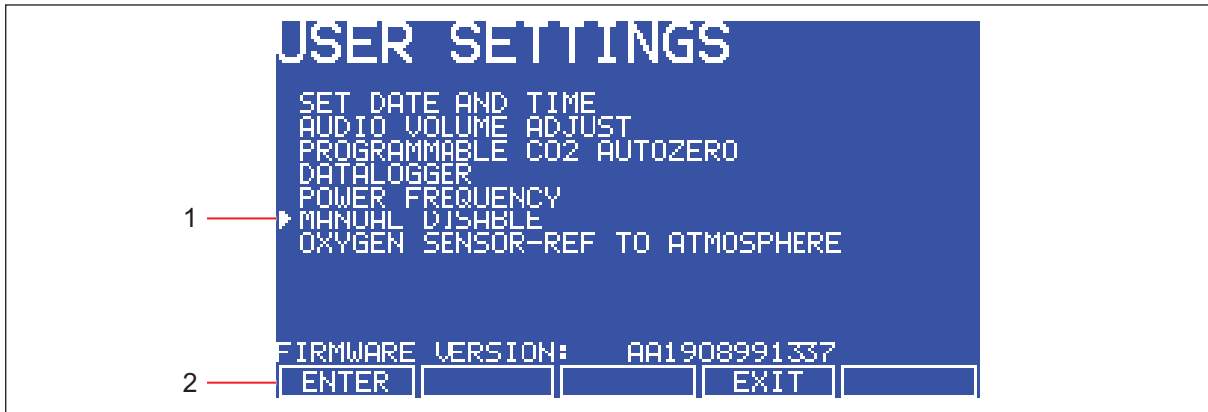

Fig. 6-2: USER SETTINGS screen

- 1 Use the ▲ and ▼ direction keys to move the cursor
- 2 Use the ENTER function key to select an option

This section explains each of the **USER** screen features. There are other **USER** options that may be displayed on screen if they are installed on your incubator. For a list of available options (see *Available options* on p. 64).

## Operating controls and function for Galaxy 170 R Incubator

Galaxy® 170 R/170 S CO<sub>2</sub> Incubators

English (EN)

### 6.4.1 SET DATE AND TIME

The date and time is factory set and will only require adjustment if you are in a different time zone, or when you change your clocks to Daylight Saving Time and back again to Standard time. You may also select the style of display for the date.

### 6.4.2 AUDIBLE ALARM VOLUME ADJUST

The audible alarm volume can be adjusted to your own preferences.

### 6.4.3 PROGRAMMABLE CO<sub>2</sub> AUTOZERO

When you select this feature, the PROGRAM CO<sub>2</sub> AUTOZERO screen (see Fig. 6-3 on p. 34) allows you to program the Auto-Zero frequency and time, or to run the Auto-Zero function manually.

We recommend that you Auto-Zero the CO<sub>2</sub> system:

- Prior to using the incubator for the first time.
- Once a month when your incubator is operating, to ensure that the CO<sub>2</sub> level is as accurate as possible.
- After the incubator has been in storage (or transit) for a while.

The Auto-Zero System automatically re-references the CO<sub>2</sub> Sensor to atmospheric CO<sub>2</sub> in the following way:

1. A pump activates for two minutes, pumping atmosphere at 0.3 liters/minute into the sensor's measuring chamber. This displaces the chamber atmosphere completely from the sensor.

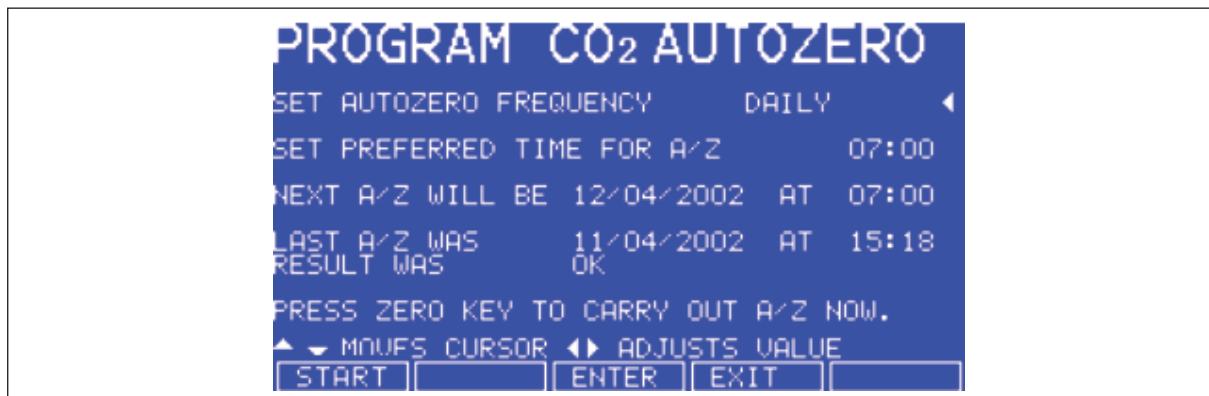

Fig. 6-3: PROGRAM CO<sub>2</sub> AUTOZERO screen



This procedure does not affect the internal chamber environment and will not affect your cell culture as it is being performed.

2. At the end of the countdown, the control system adjusts the Auto-Zero Factor to reference the sensor to 0.05 % CO<sub>2</sub>, which is the approximate atmospheric level.
3. The pump switches off and the chamber atmosphere diffuses back into the sensor's measuring chamber. This takes three minutes, after which the normal CO<sub>2</sub> control system takes over.

4. The result of the Auto-Zero (listed as *A/Z* on some screens) is sent to the **DATALOGGER ALARM EVENTS** screen so that a record of the results will be kept.

The frequency of Auto-Zeroing can be set in steps between once a day and once every 28 days. The default setting is once every 28 days. If not required, it can be disabled (see *DISABLE* on p. 35).

The default time setting is 7:00 am. This can be altered to suit your requirements. We recommend that you only change the time setting shortly before you start to use the incubator.



The Auto-Zero will only occur if the temperature is at setpoint. If the temperature is not at setpoint, the system will postpone Auto-Zero until the setpoint is achieved.

If the Auto-Zero function is to be run manually, simply press the **START** function key, within the **PROGRAM CO<sub>2</sub> AUTOZERO** window.

#### 6.4.4 DATALOGGER

For detailed information (see *DATALOGGER screen* on p. 36).

#### 6.4.5 POWER FREQUENCY

You can adjust the power frequency to either 50 or 60 Hz to match the local mains/electrical supply. Use the ◀ or ▶ direction key until the correct frequency is displayed, then press the **ENTER** function key.

#### 6.4.6 DISABLE

This feature allows you to inform the control system to ignore certain sensors if their function is not required. The standard item on this menu is the **CO<sub>2</sub> PRESSURE SWITCH** (for Auto-Zeroing). Additional Disable Options appear on this screen according to the options installed on your incubator, (see *Available options* on p. 64).

To disable a feature, scroll to **OFF** using the ◀ and ▶ direction keys, then press the **ENTER** function key.

#### 6.4.7 DISINFECTION (optional)



---

#### **NOTICE! Risk of material damage**

- ▶ The humidity tray **MUST** be empty and dry before running high-temperature disinfection.
- 

If the incubator is supplied with the High Temperature Disinfection option, the menu item **DISINFECTION** will be displayed. This feature activates the disinfection cycle of the incubator.

The disinfection cycle heats the inner chamber to 120 °C, holds that temperature for 4 hours, then cools the chamber to the selected temperature setpoint. All of the interior components (with the exception of the O<sub>2</sub> sensors, if present) can be left in place during the cycle to ensure that everything within the chamber is

disinfected prior to resumption of activity. For a full explanation of this feature, (see *High temperature disinfection option with oxygen control on p. 71*).

## 6.5 DATALOGGER screen

The *DATALOGGER* screen displays the following information:

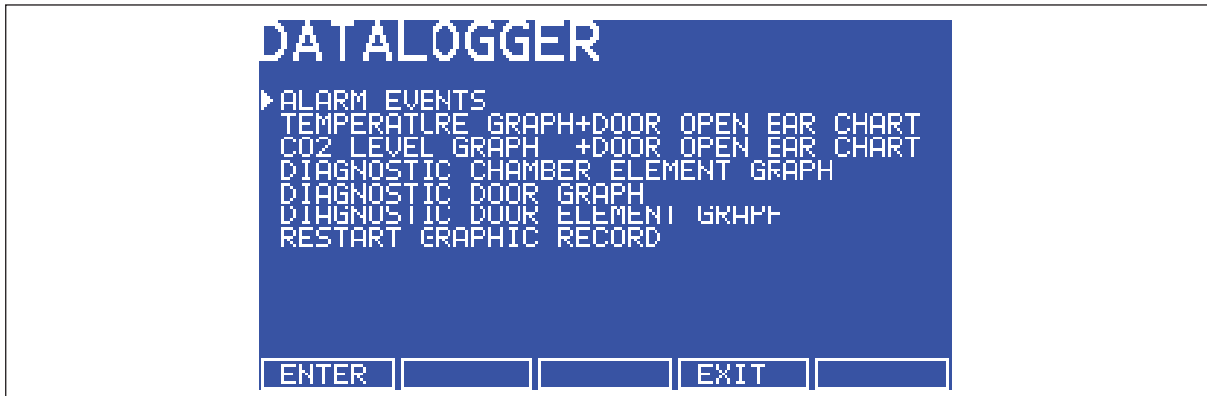

Fig. 6-4: *DATALOGGER* screen

### 6.5.1 ALARM EVENTS

The following alarm events are recorded in the order in which they occurred, with the most recent event displayed at the top:

- Power ON/OFF
- Chamber Temperature High/Low (programmed value)
- CO<sub>2</sub> Level High/Low (programmed value)
- CO<sub>2</sub> Supply Failure
- All System Alarms
- CO<sub>2</sub> Auto-Zero (A/Z) Adjustments
- CO<sub>2</sub> Auto Gain (A/G) Adjustments (*reserved for use by authorized service technicians only*)
- Oxygen and Relative Humidity (R/H) Alarms (where these options are installed)

The capacity is 99 events, after which the earliest event is overwritten and a later event is added.

The date and the time are also recorded for each event, (see Fig. 6-5 on p. 37):



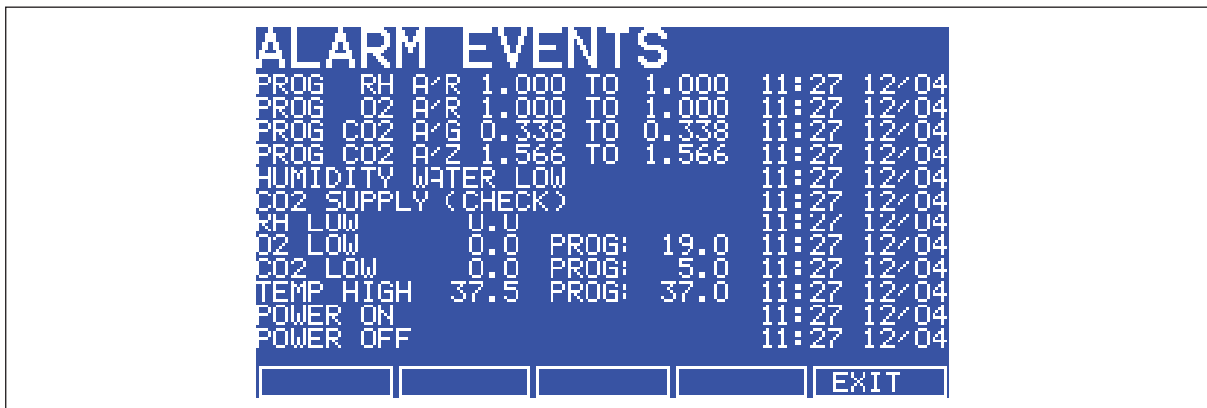

Fig. 6-5: ALARM EVENTS screen

### 6.5.2 TEMPERATURE GRAPH + DOOR OPEN BAR CHART

When you select this from the *DATALOGGER* screen, the *Door Open* bar chart is shown at the top of the screen to associate it with a temperature disturbance (see Fig. 6-6 on p. 38). A temperature reading is recorded every 18 seconds while the temperature is outside the specification of  $\pm 0.1$  °C and each reading is shown as a single pixel.

When the temperature has settled within specification, the recording is compressed to one pixel representing (10) 18-second readings (as long as the temperature remains in specification). This allows up to 10 hours of readings to be displayed on one screen. When the temperature moves outside specification, for instance if the door is opened, the graph reverts to individual 18-second readings until temperature is within specification again.

When the data is compressed or decompressed, a light dotted line is displayed vertically on the screen to signify that the time axis is changing from 18-second to 10 x 18-second increments or vice versa (see Fig. 6-7 on p. 38).

A heavy dotted line (not shown) is displayed when the incubator is switched on.

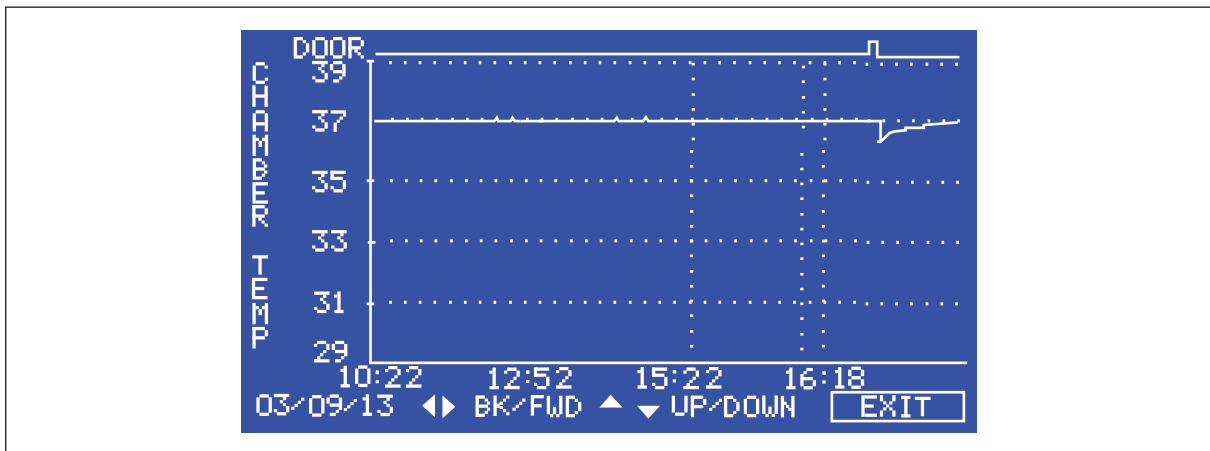

Fig. 6-6: TEMPERATURE GRAPH + DOOR OPEN BAR CHART screen

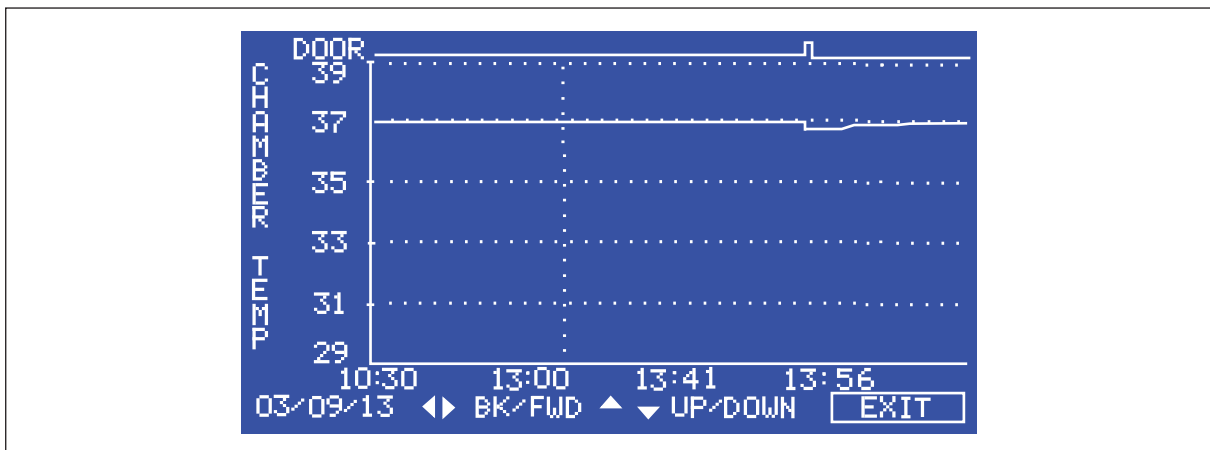

Fig. 6-7: Dotted vertical line showing compressed/decompressed data.

Compressing data allows memory space to be maximized. Once the memory space has been filled, the earliest events are overwritten as they are replaced by the latest recording.

### 6.5.3 CO<sub>2</sub> GRAPH + DOOR OPEN BAR CHART

These graphs record in a way similar to the Chamber Temperature graphs. The specification for CO<sub>2</sub> is  $\pm 0.1\%$ .



Both CO<sub>2</sub> and temperature graphs share the same time axis. If the time axis changes to accommodate data in one graph, it will also change in the other graph.

### 6.5.4 DIAGNOSTIC CHAMBER ELEMENT GRAPH

This graph records chamber element temperature over time to assist troubleshooting.

### 6.5.5 DIAGNOSTIC DOOR GRAPH

This graph records the door's inner surface temperature over time to assist troubleshooting.

### 6.5.6 DIAGNOSTIC DOOR ELEMENT GRAPH

This graph records door element temperature over time to assist troubleshooting.

### 6.5.7 RESTART GRAPHIC RECORD

This feature removes the current graph and begins a new one. The data cannot be recovered once it is deleted.

## 6.6 CHAMBER ALARMS menu screen

The *CHAMBER ALARMS* programming screen (see Fig. 6-8 on p. 39) allows the various alarm options to be selected and modified. Press the ▲ or ▼ direction key to move around the options and the ◀ or ▶ direction key to adjust values. The temperature and CO<sub>2</sub> High and Low Alarm setpoints automatically adjust to within ± 0.5 of the temperature and CO<sub>2</sub> setpoints. The alarm setpoints can also be manually adjusted.

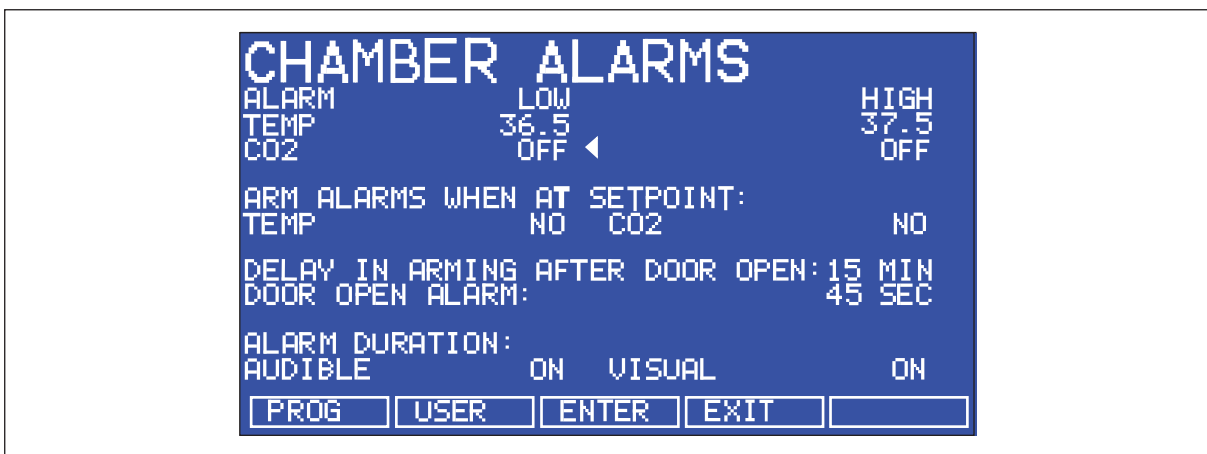

Fig. 6-8: *CHAMBER ALARMS* screen

To arm the chamber alarms after a selectable delay:

1. Choose the option *ARM ALARMS WHEN AT SETPOINT*.
2. Select *NO* for both *TEMP* and *CO<sub>2</sub>* (see Fig. 6-8 on p. 39).
3. Choose the option *DELAY IN ARMING AFTER DOOR OPEN* and select the desired delay (15 minutes in the sample screen (Fig. 6-8 on p. 39)) to allow for temperature and CO<sub>2</sub> recovery after the door has been opened.

Alternatively, the alarm system can be set to re-arm only after the original temperature and CO<sub>2</sub> setpoints have been achieved:

1. Choose the option *ARM ALARMS WHEN AT SETPOINT*.

## Operating controls and function for Galaxy 170 R Incubator

Galaxy® 170 R/170 S CO<sub>2</sub> Incubators

English (EN)

2. Select *YES* for both *TEMP* and *CO<sub>2</sub>*.
3. When *YES* is selected for this function, the *DELAY IN ARMING AFTER DOOR OPEN* is ignored.

A *DOOR OPEN ALARM*: can be adjusted, choosing from seven preset durations (45 seconds in (Fig. 6-8 on p. 39)) to warn of an improperly closed door.

The *AUDIBLE* and *VISUAL* alarms can be adjusted from *OFF* to *ON* (which means the alarm will be on continuously until it is acknowledged) in seven preset time increments.

In the *OFF* position, any Chamber Alarms that occur will be displayed on the screen without flashing and with the audible alarm inhibited (see *Chamber alarm system function* on p. 40).

### 6.6.1 Chamber alarm system function

When the incubator is switched *ON*, or after the temperature and CO<sub>2</sub> levels have been re-programmed, the alarm system is inactive until the setpoint values are achieved (within  $\pm 0.1$ ), after which the alarm system is armed. CO<sub>2</sub> and temperature alarms are individually armed.

If temperature and/or CO<sub>2</sub> levels deviate more than the programmed setpoints, the display flashes, the audible alarm sounds and a message appears on the screen (see Fig. 6-9 on p. 40). Acknowledge the alarm by pressing any key.

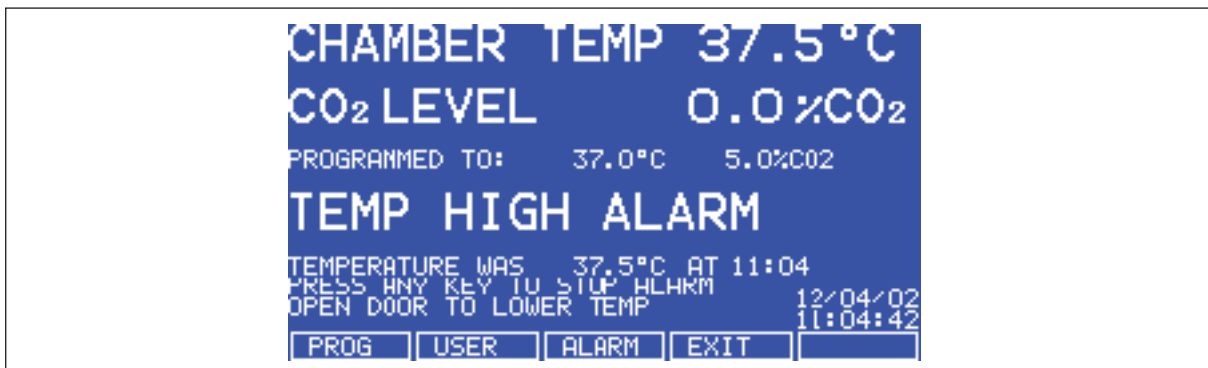

Fig. 6-9: *CHAMBER ALARM* message

After setpoints have been achieved for the first time, when the outer door is opened, the alarm system is disabled; on closing the door, if selected, a programmable alarm delay starts:

- If chamber conditions recover within the programmed alarm delay time, the alarm system is immediately re-armed. After the delay, the alarm system is armed and if the temperature and CO<sub>2</sub> are outside the alarm high and low settings, the alarm will be activated.
- If an alarm occurs and the chamber subsequently recovers, the alarm stops and the system is re-armed. Details of the alarm event are stored in the datalogger.

If the CO<sub>2</sub> valve is opened and no pressure is detected, an alarm occurs and a warning message appears on the screen, alerting you to *CHECK CO<sub>2</sub> SUPPLY* (see Fig. 6-10 on p. 41).

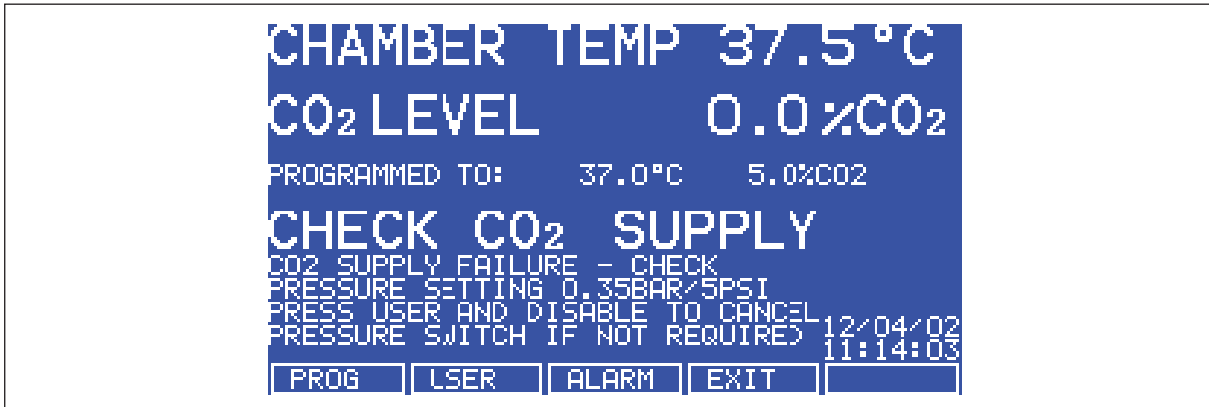

Fig. 6-10: CHAMBER ALARM to check CO<sub>2</sub> supply

Instructions to remedy the alarm are provided in the ALARM screen.

### 6.7 DIAGNOSTICS menu screen

The diagnostics screen contains technical information regarding the status of many of the system components found on the incubator. This screen is mainly for technical service use, and can be used to troubleshoot the incubator systems before service is scheduled. This information allows technical support to optimize the service support required, and to shorten service time.

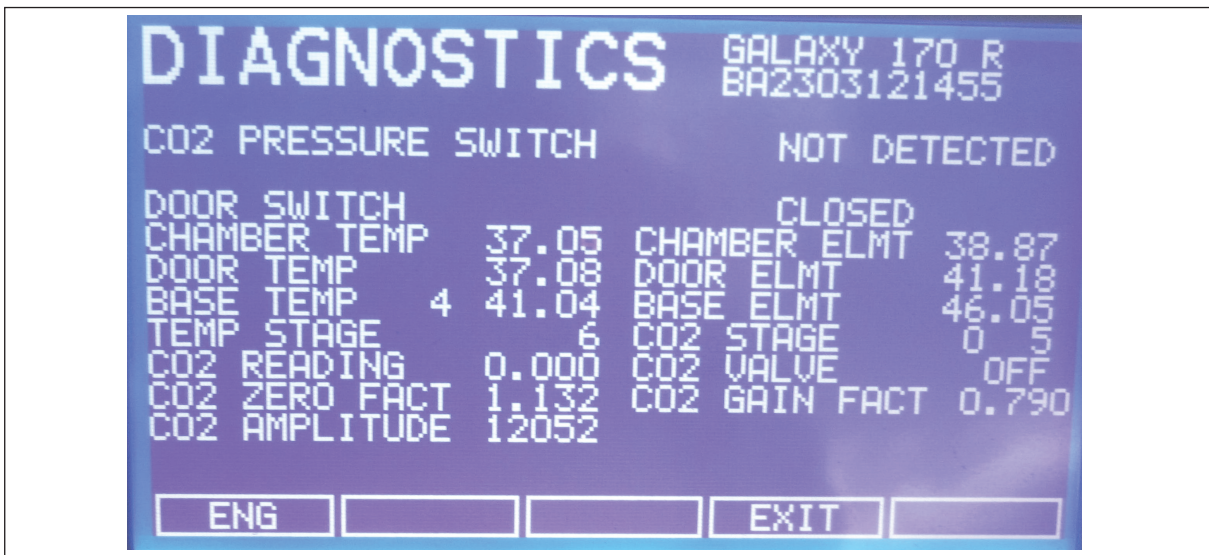

Fig. 6-11: DIAGNOSTICS screen

## 6.8 HELP MENU screen

The *HELP MENU* screen provides user-selectable categories of abbreviated information found in the user manual. All the major systems are covered in the help menu, including help on installing the incubator. If the user manual is misplaced, information about the CO<sub>2</sub> incubator and its functions can always be found on-screen.



Fig. 6-12: *HELP MENU* Screen

## 7 Operating controls and function for Galaxy 170 S Incubator

### 7.1 170 S control panel

The control panel consists of two individual three-digit LED displays, and four function keys:

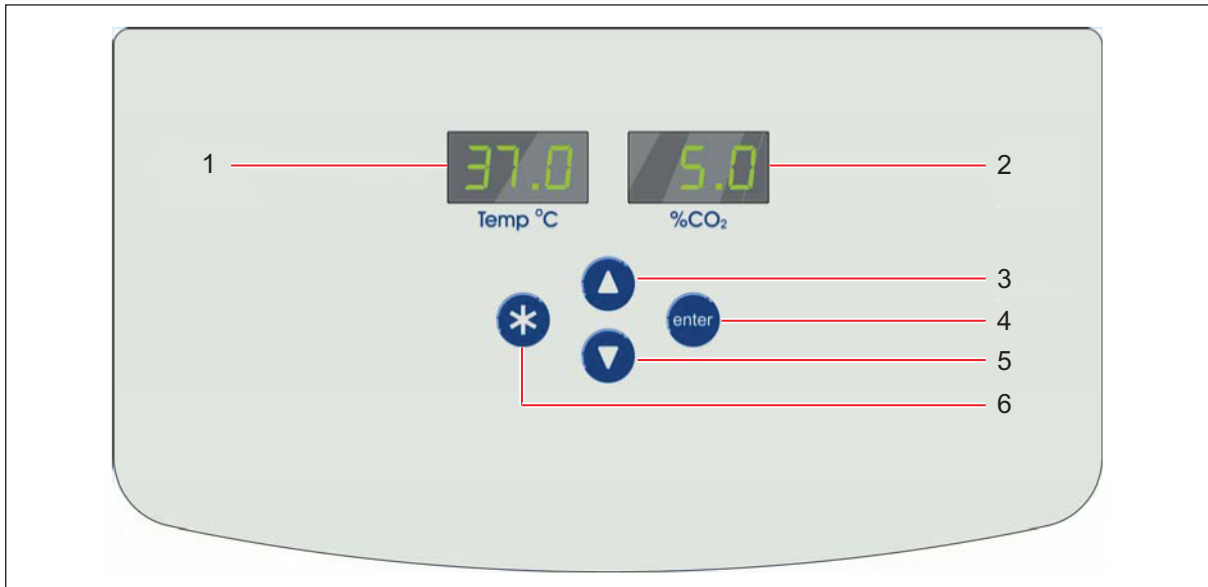

Fig. 7-1: Galaxy 170 S control panel (normal operation)

**1 Temperature display**

**2 CO<sub>2</sub> display**

**3 Up (function key)**

In Programming mode, use this key to scroll up through numbered values in the display

**4 Enter (function key)**

Press this key to save a new setpoint. Press this key simultaneously with the Down key to access the Alarm system

**5 Down (function key)**

In Programming mode, use this key to scroll down through numbered values in the display. Press this key simultaneously with the Enter key to access the Alarm system

**6 Programming (function key)**

Press this key to enter Programming mode, and to set values in either display



If you accidentally press both the Up and Down keys simultaneously, you will engage Engineering Mode: press the Programming key immediately to exit.

## Operating controls and function for Galaxy 170 S Incubator

Galaxy® 170 R/170 S CO<sub>2</sub> Incubators

English (EN)

### 7.2 Setting temperature and CO<sub>2</sub>

Perform the following steps to program the temperature and CO<sub>2</sub> setpoints. Temperature and CO<sub>2</sub> may be set within the ranges shown in the following table:

Tab. 7-1: Setting temperature and CO<sub>2</sub>

Parameter	Available Setpoint Range
Temperature	10 °C to 50 °C (must be at least 4 °C above ambient)
CO <sub>2</sub>	0.2 % to 20 %

To set the Temperature:

1. Press the **Programming** ( \* ) key.  
The temperature display will flash.
2. Press the Up (▲) or Down (▼) key until the desired value appears in the left-hand display.
3. Press the **Enter** key to save the setpoint.  
The CO<sub>2</sub> display will flash.

To set the CO<sub>2</sub> level:

1. Press the up (▲) or down (▼) key until the desired value appears in the right-hand display.
2. Press the **Enter** key to save the setpoint.

To change the CO<sub>2</sub> level without adjusting the temperature setpoint, press the **Programming** ( \* ) key to work in the CO<sub>2</sub> display, then press the **Enter** key.



Allow the incubator to stabilize at the setpoints selected before continuing.

### 7.3 Programming the alarm system

#### 7.3.1 Setting the high and low temperature alarms

1. Press the **Enter** and ▼ keys simultaneously to enter the alarm menu.  
The display will show: °C.AL.
2. Press the **Enter** key to display the High Temperature Alarm, *HI 37.5*. The factory setting is the setpoint value (37.0 °C) + 0.5 °C.
3. Use the Up (▲) or Down (▼) key to adjust the High Temperature Alarm. The minimum setting is 0.5 °C from setpoint.
4. Press the **Enter** key to save the setting.  
The Low Temperature Alarm is displayed, *LO 36.5*. The factory setting is the setpoint value (37.0 °C) - 0.5 °C.
5. Use the Up (▲) or Down (▼) key to adjust the value.



6. Press the **Enter** key to accept the setting.
7. Press the **Programming** ( \* ) key twice to exit the menu.

### 7.3.2 Setting the CO<sub>2</sub> high and low alarms

1. Press the **Enter** and ▼ keys simultaneously to enter the alarm menu.  
The display will show: °C.AL.
2. Press the ▲ key until the display shows: CO<sub>2</sub>AL.
3. Press the **Enter** key to display HI.5.5. The factory setting is the setpoint value (5.0 %) + 0.5 %.
4. If you wish to adjust the High CO<sub>2</sub> Alarm, use the ▲ or ▼ key. The minimum setting is 0.5 % from setpoint.
5. Press the **Enter** key to save the setting.  
The low CO<sub>2</sub> Alarm is displayed, LO 4.5. The factory setting is the setpoint value (5.0 %) - 0.5 %.
6. Use the the ▲ or ▼ key to adjust the value.
7. Press the **Enter** key to accept the setting.
8. Press the **Programming** ( \* ) key twice to exit the menu.



If the CO<sub>2</sub> setpoint is programmed at 0.0 % and high and low alarms are accessed, the high will display "0.5" and the low will display "Off".

### 7.3.3 Door open alarm

When the door is opened, an alarm will sound after a preset time delay. To adjust the time delay:

1. Press the **Enter** and ▼ keys simultaneously to enter Alarm Program Mode.  
The display will show: °C.AL.
2. Press the ▲ key until the display shows DOO.RAL (reading across both displays).
3. Press the enter key and the ▲ and ▼ keys to adjust the time (as you scroll through the available choices, you will see 15, 30, 45, 60, 75, 90 seconds, then OFF).
4. Press the **Enter** key to save the desired value.
5. Press the **Programming** ( \* ) key twice to exit the menu.

### 7.3.4 Alarm duration

Perform the following steps to adjust the alarm duration:

1. Press the **Enter** and ▼ keys simultaneously to enter Alarm Program Mode.  
The display will show: °C.AL.
2. Press the ▲ key until the display shows PER.IOD (reading across both displays).
3. Press the **Enter** key and the ▲ and ▼ keys to adjust the Alarm duration.

## Operating controls and function for Galaxy 170 S Incubator

Galaxy® 170 R/170 S CO<sub>2</sub> Incubators

English (EN)

As you scroll through the available choices, you will see *OFF, 10 sec, 30 sec, 60 sec, 600 sec, 1 HR*, then *ON*).

4. Press the **Enter** key to select the desired value.
5. Press the Programming ( \* ) key twice to exit the menu.

### 7.3.5 Alarm arming delay

The alarm arming delay is the length of time that is allowed for the Temperature and CO<sub>2</sub> to recover after opening the incubator before the Alarm System is armed again. This helps to prevent unnecessary alarms from occurring.

To change the delay:

1. Press the **Enter** and ▼ keys simultaneously to enter Alarm Program Mode.  
The display will show: °C.AL.
2. Press the ▲ key until the display shows *DR .DEL* (across both windows).
3. Press the **Enter** key and the ▲ and ▼ keys to adjust the Alarm Arming time.  
As you scroll through the available choices, you will see *0.15 Hr, 0.20, 0.30, 1.00* , then *OFF*.
4. Press **Enter** to select the desired value.
5. Press ( \* ) to return to the main alarm programming menu, and press ( \* ) again to return to the main display.



When alarm delay is set to OFF, the Alarms will arm only when the programmed setpoint is reached.

## 7.4 Chamber alarm system

When the incubator is switched **ON**, or after any values have been reprogrammed, the Alarm System is inactive until the setpoint values ( $\pm 0.1$ ) are achieved, after which the Alarm System is armed.

If temperature and/or CO<sub>2</sub> levels deviate more than the programmed amount, the display flashes, the audible alarm sounds and a message appears on the screen. You can acknowledge (and cancel) the alarm by pressing any key.

When the outer door is opened, the Alarm System is disabled. When you close the door, the preset Alarm Arming Delay starts. When the delay time expires, the Alarm System is re-armed; if the temperature and/or CO<sub>2</sub> fall below or above the alarm setpoints, the alarm will be activated. If chamber conditions recover within the Alarm Arming Delay time, the Alarm System will be re-armed but no alarm will be activated.

If an alarm is not acknowledged but the chamber conditions subsequently recover, the audible alarm will be cancelled but the alarm message will remain on the screen to alert the user to the fact that an alarm has occurred. You can cancel this alarm message by pressing any key. The duration of the audible alarm can be adjusted from inactive to continuous (see *Alarm duration on p. 45*).

### 7.4.1 Temperature sensor system alarms

There are six temperature sensors: two in the chamber, two in the door and two in the base. If any of these sensors should fail, the following message will appear: *°C F.AIL*.

Because the incubator can no longer control temperature properly without the failed sensor, the heating will switch off and the incubator will cool down to room temperature.

If, however, a sensor fails but subsequently corrects itself, the temperature control will restart and an alarm message will remain on the temperature side of the display: *SAL ...* (meaning Sensor Alarm).

This message can be cancelled by pressing any key.

### 7.4.2 Over-temperature cut-out and alarm

This alarm only occurs if the chamber temperature exceeds the temperature setpoint by 1 °C or if one of the heating elements exceeds a specific activation threshold. The activation threshold is set at the factory and cannot be adjusted.

Following activation, the over-temperature cut-out and alarm system operates in two sequential modes:

**Mode 1:** The over-temperature cut-out and alarm activates and cuts power to the heating elements and the CO<sub>2</sub> control valve. The condition is shown on the display by the message *°Ctrip*. When the chamber temperature has fallen to the programmed setpoint, the system changes to Mode 2.

**Mode 2:** The control system then tries to maintain the chamber temperature at the programmed level by switching the heating elements on and off, using an emergency control method that is, however, less precise. The message *TAL* will flash on-screen to signal that an over-temperature fault occurred and the incubator is being controlled by the emergency control system. This message cannot be cancelled via the keypad.

Normal temperature control can be regained and the over-temperature cutout and alarm can be cancelled by reprogramming the temperature, opening and closing the glass door, or switching the incubator off and back on.

If the problem persists, the alarm will recur; if this happens, please contact your service representative or your distributor immediately.

## 7.5 CO<sub>2</sub> Auto-zero system

Perform the following steps to carry out an auto-zero and reference the CO<sub>2</sub> sensor to atmospheric CO<sub>2</sub>

### 7.5.1 Auto-zero

1. Press the **Enter** and **Programming** ( \* ) keys simultaneously.

A prompt will appear:

*ENT.ER STA.RTS CO2 AUT.O ZER.O*

## Operating controls and function for Galaxy 170 S Incubator

Galaxy® 170 R/170 S CO<sub>2</sub> Incubators

English (EN)

2. Press the **Enter** key to begin the cycle.

The Auto Zero System automatically re-references the CO<sub>2</sub> Sensor to atmospheric CO<sub>2</sub> in the following way:

- A small pump switches on for 2 minutes pumping filtered atmosphere at 0.3 liters/minute into the measuring chamber of the sensor. This displaces the chamber atmosphere completely from the sensor.
- At the end of the countdown, the Control System adjusts the auto-zero factor to reference the sensor to 0.05 % CO<sub>2</sub> which is the approximate atmospheric level.
- The pump switches off and chamber atmosphere moves back into the measuring chamber of the sensor. This takes 3 minutes after which the normal CO<sub>2</sub> control takes over.
- On completion of the auto-zero a prompt will appear:

*CO2 AUT.O ZER.O IN RAN.GE*

3. Press the ( \* ) key to finish the cycle and return to the main display.

If the CO<sub>2</sub> Auto-Zero cannot reference the signal to atmosphere at the end of the Auto-Zero, the following message will appear:

*CO2 AUT.O ZER.O FAIL.ED*

This means that the CO<sub>2</sub> sensor is defective and requires replacement. If this occurs, please contact your local distributor immediately.

The default setting for the auto-zero system is 28 days of running time for the incubator. After the incubator has been switched on for a total of 28 days (672 hours), the auto-zero will automatically take place.

### 7.5.2 Changing auto-zero frequency

To change the frequency of the auto-zero

1. Press the **Enter** and ▲ keys simultaneously.

The following message will be displayed: *PRG.A2*.

2. Press **Enter**.

The display changes to *28 DAY*.

By pressing the ( \* ) and enter keys this value can be changed in steps from *28* to *14*, *7*, *1* or *OFF*.

3. Press **Enter** to confirm the new setting.

If a CO<sub>2</sub> alarm occurs, the auto-zero will automatically take place after 1 minute. This is to confirm that the CO<sub>2</sub> sensor is correctly referenced.

If after a 15-minute delay, the CO<sub>2</sub> is still in an alarm condition and re-alarms, it will again auto-zero.

In the event of high CO<sub>2</sub> alarms, open the inner door for a few seconds to ensure that the CO<sub>2</sub> level drops below setpoint. Also check that the CO<sub>2</sub> pressure is set correctly to 5 PSI (0.35 bar).

In the event of low CO<sub>2</sub> alarms, check that the CO<sub>2</sub> supply is present and set to the correct pressure.

### 7.5.3 High temperature disinfection operation

For high temperature disinfection information (see *Using the high temperature disinfection (Galaxy S)* on p. 70).

**Operating controls and function for Galaxy 170 S Incubator**

Galaxy® 170 R/170 S CO<sub>2</sub> Incubators  
English (EN)

## 8 Maintenance

### 8.1 Routine maintenance

#### 8.1.1 General



**WARNING! Risk of injury to personnel or damage to equipment!**

- ▶ Two stacked incubators should not be moved for maintenance or cleaning.
- 

To ensure that chamber conditions remain stable, minimize the length of time that the door is open. When you open the door, wipe off any condensation that may have formed on the inner seal to avoid condensation build-up.

If you are using the humidity tray for humidification, (see *Using the humidity tray on p. 30*).



If you have two incubators stacked, the upper incubator does not have to be moved when you are servicing the lower incubator.

#### 8.1.2 Daily Checks

1. Check that the temperature and CO<sub>2</sub> levels are reading within specification.
2. Check the reserve pressure in the CO<sub>2</sub> cylinder (normally 725 PSI (50 bar) when full). The design of the incubator ensures very low consumption of CO<sub>2</sub>: during normal working conditions, a typical large cylinder should last approximately 12 months (frequent door openings will deplete the supply more rapidly). If there is a significant drop at the cylinder pressure of 725 PSI (50 bar), it means that the cylinder is almost empty and should be replaced. Ensuring that there are no leaks at any of the connections will ensure a greater lifetime to the CO<sub>2</sub> supply and will help avoid accidentally running out of CO<sub>2</sub>.
3. Any spills in the chamber should be cleaned immediately.
4. Check the **DATALOGGER** screen for any alarms or events that may have occurred overnight.

#### 8.1.3 Weekly checks



Use distilled water only in the humidity tray. Use of any other types of water including deionized water will cause corrosion inside the incubator.

Refill the humidity tray with 1.5 - 2.5 liters of warm (~ 37.0 °C) distilled water. The use of warm water will ensure a rapid return to optimum chamber conditions.

#### 8.1.4 Monthly checks

We recommend routine replacement of the water in the humidity tray, and that you clean the tray at the same time.

**Maintenance**

Galaxy® 170 R/170 S CO<sub>2</sub> Incubators  
English (EN)

If required, you can take a sample of the gas inside the chamber using the CO<sub>2</sub> sample port, and check it using a CO<sub>2</sub> gas analyzer (see *Accessories on p. 63*)(see *CO<sub>2</sub> Sampling with analyzer on p. 52*).



Displayed chamber CO<sub>2</sub> level will drop during sampling, but it will recover once the sampling is complete. This is merely a sensor characteristic; the CO<sub>2</sub> level in the chamber is actually not affected.

We recommend that you perform a CO<sub>2</sub> Auto-Zero prior to sampling. We also recommend that you Auto-Zero the CO<sub>2</sub> system at least once every 28 days to ensure that CO<sub>2</sub> level is correct.

### 8.1.5 CO<sub>2</sub> Sampling with analyzer

The CO<sub>2</sub> sample port is located on the left-hand side of the incubator, near the top (see Fig. 5-1 on p. 29).

If you conduct a sampling, please ensure the following:

- Turn off the CO<sub>2</sub> gas by re-programming the setpoint for CO<sub>2</sub> to 0.0 % to prevent CO<sub>2</sub> from being injected into the chamber and giving a false reading.
- A flow rate ≤ 0.5 liters/minute is used to take a sample.
- The door is kept closed.
- Reset the CO<sub>2</sub> setpoint to the desired level after sampling.



We recommend that you perform a CO<sub>2</sub> Auto-Zero prior to sampling. We also recommend that you Auto-Zero the CO<sub>2</sub> system at least once every 28 days to ensure that CO<sub>2</sub> level is correct.

### 8.1.6 Routine checks of the O<sub>2</sub> control option (170 R only)

Be sure to conduct the reference to atmospheric oxygen procedure on a monthly basis to ensure that long-term drift in output from the sensor will be corrected, and to determine when the sensor requires replacement.

Under normal humidity conditions (95 - 99 % RH), the sensor is unaffected. If for any reason (such as a large spill inside the chamber or the incubator being switched off while fully humidified) liquid condenses around the sensor, the result may be restriction of gas flow and a low sensor signal. Should such condensation appear on the chamber walls, normal operation can be easily restored by removing the humidity tray, drying the chamber completely, and then running the incubator at 37 °C for one hour. This will dry out the sensor. After the hour has elapsed, the humidity tray can be reinstalled and the incubator humidified again.

Change the hydrophobic filter **each time** you clean the incubator, to avoid contamination or clogging over time.



## 8.2 Service

### 8.2.1 Fuse replacement



**DANGER! Electric shock**

- ▶ Switch the device off and pull the power plug out of the socket before beginning work.
- 

To replace a fuse, you will need a flat-bladed (5 mm maximum) screwdriver.

1. Using the flat-bladed screwdriver, rotate the fuse holder (see Fig. 4-7 on p. 27) counter-clockwise until the fuse holder springs out.
2. Remove the spent fuse.
3. Install a new fuse of the same type.
4. Orient the fuse holder back in the side panel and, using the screwdriver, turn clockwise to secure it in place.

## 8.3 Cleaning



**DANGER! Electric shock**

- ▶ Switch the device off and pull the power plug out of the socket before beginning work.
- 



**NOTICE! Damage due to incorrect cleaning agent or sharp objects**

Unsuitable cleaning agents can damage the display, surfaces and printing.

- ▶ Never use corrosive cleaning agents, strong solvents or abrasive polishes.
  - ▶ Do not use acetone to clean the device.
  - ▶ Do not use sharp objects to clean the device.
- 

1. Routinely clean the exterior of the incubator by wiping it over with a soft cloth, moistened with soapy water.
2. Rinse the soap from the cloth in clean water, and wipe the exterior surfaces again.

## 8.4 Disinfection/Decontamination



**DANGER! Danger from exposure to decontamination agents.**

- ▶ Wear appropriate laboratory clothing, protective gloves and safety glasses.
- ▶ Wear breathing protection if you work with particulate matter.

**Maintenance**

Galaxy® 170 R/170 S CO<sub>2</sub> Incubators  
English (EN)

**NOTICE! Risk of material damage**

- ▶ Never use any of the following substances to clean the stainless steel, or damage will result: Sodium Azide, Aqua Regia, Iodine, Ferric Chloride or Sulphuric Acid.



Use the decontamination method recommended by the manufacturer.

If you would like to use a different method, contact Eppendorf to prevent the device from becoming damaged.

If you have any further questions regarding the cleaning and disinfection or decontamination and the cleaning agents to be used, contact Eppendorf.

The contact details are provided on the back of this manual.

**NOTICE! Risk of material damage**

- ▶ It is very important to ensure that no liquid is spilled onto the white porous CO<sub>2</sub> sensor cover at the rear of the chamber. Failure to use the protective cover(s) could result in damage to the sensor(s) and may affect your warranty.



Use distilled water only in the humidity tray. Use of any other types of water including deionized water will cause corrosion inside the incubator.

The recommended disinfecting agent for use with the incubator is a solution of 70 % isopropanol (isopropyl alcohol) and 30 % distilled water. Be sure to follow appropriate safety regulations while you are using this solution.

To best protect yourself, your incubator and your work area, follow these instructions:

1. Program 0.0 % CO<sub>2</sub> and switch off the incubator. Unplug the incubator from the mains/power supply.

**external**

2. Dampen a clean cloth with the alcohol solution and wipe down all surfaces, taking care to keep the alcohol solution from coming into contact with any mains/electrical outlets or assemblies.
3. Remove all of the shelves, the humidity tray, and the shelf racks.
4. Place the black protective cover over the CO<sub>2</sub> sensor. Also protect any additional sensors, such as Oxygen or Humidity, with the cover(s) supplied.
5. You can clean the humidity tray by rinsing it in sterile water, wiping it down with the alcohol solution, and then rinsing it again with sterile water.
6. Wipe down the inside of the chamber with the alcohol/water solution, and leave it to dry completely.

**internal**

7. Wipe the components of the chamber twice with the alcohol/water solution. Wipe off excess liquid and leave it to dry completely.
8. Reassemble the shelf racks, shelves, and humidity tray before switching the incubator on. Wipe the inner door seal with the alcohol solution, rinse and leave it to dry.
9. Ensure the protective cover(s) are removed from all sensor(s) and replaced in the holder for safekeeping. Be very careful, as you remove the black CO<sub>2</sub> sensor cover, not to accidentally remove the white porous sensor cover. This must remain in place.

10. Refill the humidity tray (see *Using the humidity tray on p. 30*). When you reinstall it, ensure that the humidity tray is pushed fully back.
11. Leave the incubator on for at least two hours (preferably overnight) to allow conditions to stabilize.
12. When the incubator has stabilized, carry out an Auto-Zero and reprogram the desired CO<sub>2</sub> level. It may be necessary to open the glass door briefly if, after performing an Auto-Zero, the CO<sub>2</sub> level is too high.

## 8.5 High temperature disinfection

If your incubator is supplied with the High Temperature Disinfection option, follow the guidelines outlined for operation, (see *Using the high temperature disinfection (Galaxy R) on p. 68*) or (see *Using the high temperature disinfection (Galaxy S) on p. 70*) for information on how to correctly and safely operate this option.

**Maintenance**

Galaxy® 170 R/170 S CO<sub>2</sub> Incubators  
English (EN)

## 9 Transport, storage and disposal

### 9.1 Transport



#### NOTICE! Risk of material damage

- ▶ Never try to lift the incubator by its door; this would cause permanent damage to the incubator.

### 9.2 Storage

Store incubator in ambient conditions of 10 °C - 50 °C.

### 9.3 Disposal

In case the product is to be disposed of, the relevant legal regulations are to be observed.

#### Information on the disposal of electrical and electronic devices in the European Community:

Within the European Community, the disposal of electrical devices is regulated by national regulations based on EU Directive 2002/96/EC pertaining to waste electrical and electronic equipment (WEEE).

According to these regulations, any devices supplied after August 13, 2005, in the business-to-business sphere, to which this product is assigned, may no longer be disposed of in municipal or domestic waste. To document this, they have been marked with the following identification:



Because disposal regulations may differ from one country to another within the EU, please contact your supplier if necessary.

In Germany, this is mandatory from March 23, 2006. From this date, the manufacturer has to offer a suitable method of return for all devices supplied after August 13, 2005. For all devices supplied before August 13, 2005, the last user is responsible for the correct disposal.



## 10 Technical data

### 10.1 Weight/dimensions

#### 10.1.1 Equipment dimensions

Width	68.5 cm (27 in)
Height	84.3 cm (33.2 in)
Depth	67.7 cm (26.7 in)
Weight	90 kg (198.4 lb)

#### 10.1.2 Internal dimensions

Width	53.3 cm (21.0 in)
Height	69.3 cm (27.3 in)
Depth	44.4 cm (17.5 in)
Volume	174 liters

#### 10.1.3 Transporting dimensions

Width	83.0 cm (33 in), pallet included
Height	110.0 cm (43 in), pallet included
Depth	83.0 cm (33 in), pallet included
Weight	108 kg (238 lb)

#### 10.1.4 Shelves

Width	52.0 cm (20.5 in)
Depth	42.6 cm (16.8 in)
Number of shelves (170 R)	Multi-position shelf option (standard)
Number of shelves (170 S)	4 standard; upgrade to 8 shelves with multiple position option available

**Technical data**

Galaxy® 170 R/170 S CO<sub>2</sub> Incubators  
English (EN)

**10.2 Power supply****10.2.1 Mains/electrical supply**

Mains/power connection	120 V, 50 Hz 120 V, 60 Hz 230 V, 50 Hz 230 V, 60 Hz
Power consumption for 120 V	1300 W
Power consumption for 230 V	1600 W
Energy to maintain 37 °C	< 0.1 kWh

**10.3 Fuses**

fuse for 120 V	10 A
fuse for 230 V	8 A

**10.4 Ambient conditions**

Ambient conditions	15 °C - 28 °C
--------------------	---------------

**10.4.1 Temperature management**

- Digital programming via microprocessor control in 0.1 °C increments. Measurement of chamber and door temperature via 6 RT (Resistance Temperature curve) matched thermistors (sensitivity 0.01 °C)
- Adjustable independent control of door heater
- "Out of Limits" temperature protection system independent of microprocessor control.

Range	4 °C above ambient temperature to 50 °C
Control	± 0.1 °C
Stability	± 0.1 °C at 37 °C
Uniformity	± 0.3 °C at ambient 20°C - 25 °C



If ambient temperature is close to the programmed value, control settings may need adjusting. Please consult Eppendorf Service for instructions.



### 10.4.2 CO<sub>2</sub> control

Solid-state infrared CO<sub>2</sub> sensor operating independent of humidity. Programmable, fully automatic zeroing function.

Range	0.2 - 20 %
Control	± 0.1 %
Stability	± 0.2 % at 5 % CO <sub>2</sub>
Uniformity	± 0.1 %
Gas connections	6 mm tubing
Required gas pressure	5 PSI (0.35 bar)

### 10.4.3 Relative humidity

Removable stainless steel humidity tray.

Reservoir capacity	2.5 liters
Humidity control	Normal: 95 % at 37 °C

### 10.4.4 Altitude limit

Altitude limit	2000 m (2187.23 yd)
----------------	---------------------

### 10.4.5 Storage temperature

Air temperature	10 - 50 °C
-----------------	------------

### 10.4.6 Calibration



Maximum operating ambient temperature is 28 °C.  
Factory calibration of the incubator is carried out at 37 °C, 5.0 % CO<sub>2</sub> and 90 to 95 % RH, in an ambient temperature of 20 - 25 °C with no heat-generating apparatus inside the chamber.

Software calibration adjustments may be required to optimize performance if the incubator is being used well outside these operating conditions. Performance specifications may also be affected.

For advice on calibration adjustments and relevant performance specifications, contact Eppendorf service. Please be prepared with the model and serial number of your incubator and the complete details of your operating conditions.

**Technical data**

Galaxy® 170 R/170 S CO<sub>2</sub> Incubators  
English (EN)

## 11 Ordering information

### 11.1 Accessories

Contact Eppendorf sales for ordering information.

Description	Quantity
Two Stage CO <sub>2</sub> Regulator	1
Two Stage N <sub>2</sub> Regulator	1
CO <sub>2</sub> Supply Line Filter	1
CO <sub>2</sub> In-line Pressure Regulator	1
CO <sub>2</sub> Cylinder Auto-Changeover Controller	1
Auto-Zero Filter	1
BioCommand SFI	1
Oxygen Sensor Zeroing Kit	1
Electronic CO <sub>2</sub> Gas Analyzer	1
Electronic CO <sub>2</sub> and O <sub>2</sub> Gas Analyzer	1
Electronic CO <sub>2</sub> / O <sub>2</sub> and RH Analyzer	1
Additional Shelf, Perforated	1
Additional Shelf, Non-Perforated	1
Additional Humidity Pan	1
Stacking Kit and Stand (lower and upper stacking frame with casters)	1
Lower Stacking Frame with Castors	1
Spare CO <sub>2</sub> Sensor	1
Spare O <sub>2</sub> Sensor	1

**Ordering information**

Galaxy® 170 R/170 S CO<sub>2</sub> Incubators  
English (EN)

## 11.2 Available options

Some option combinations are not possible, others may incur extra cost. Contact Eppendorf sales for ordering information.

---

**Options**

---

Cooling System

---

Galaxy 170 R BMS Relay

---

Galaxy 170 S BMS Relay

---

O<sub>2</sub> Control, 0.1 - 19 %

---

O<sub>2</sub> Control, 1 - 95 % (170 R only)

---

IP66 Power Receptacle

---

Copper Chamber

---

4 Split Inner Door\*

---

8 Split Inner Door\* (recommended for device with O<sub>2</sub> control)

---

Humidity Alert and Monitoring Package

---

\*Four and eight inner glass door options are available, to match the shelves installed, which help to reduce the loss of CO<sub>2</sub>, temperature and humidity conditions when the chamber door is opened.

## 12 Equipment options

### 12.1 Cooling system

The cooling system option allows the incubator to be used in one of three possible modes. The cooling system option consists of a heat exchanger assembly, fitted to the rear wall of the chamber, with a circulation fan.

Inside the incubator chamber, the heat exchanger cooling fins and fan are enclosed by a removable cover, with ventilation slots to facilitate airflow to the fan and to the shelves. To cool the chamber, the fan on the heat exchanger assembly circulates chamber air across the cooling fins of the heat exchanger.

Outside the chamber, the rear of the heat exchanger assembly has an external cooling fan to cool the exchanger's hot fins by blowing ambient air across them.

The three modes of operation accessible in the **USER** menu under **COOL OPTIONS** are explained in the following table.



In all operating modes the ambient room temperature is assumed to be maintained at a uniform level. Changing from one operating mode to another requires manual mode selection.

Mode	Description
NORMAL	For working at 37 °C in average ambient temperatures of 20 °C - 26 °C. In this mode, the fans and heat exchanger assembly are switched off and the heating system operates as standard, without using the cooling option. The cooling system remains inactive.
AMBIENT	For culturing at temperatures close to room ambient temperature, therefore maintaining the chamber temperature within a range close to room ambient temperature. In this mode, the fans and heat exchanger, and the heating system are switched on to balance each other.
COOL	For culturing continuously between 1 °C - 10 °C below room ambient temperature. In this mode, the cooling system operates as with AMBIENT culturing , but with the heating system deactivated.

Before running the incubator with the cooling system option, ensure that the heat exchanger assembly cover is in place, also ensure that the humidity tray is pushed fully towards the back of the chamber to prevent deflector plate condensation from draining behind the tray, onto the base of the chamber.

The heat exchanger cover can be removed for cleaning: remove it from the four keyhole studs that hold it in place by gently lifting the cover out of the key-hole slots and then lifting it away toward you, taking care not to force it; damage to the inner components could result. Be sure to reinstall the cover carefully before operating the incubator again.

**Equipment options**

Galaxy® 170 R/170 S CO<sub>2</sub> Incubators  
English (EN)

### 12.1.1 Troubleshooting the cooling system

The thermo-electric module which governs the cooling system is self-contained and does not require any specific maintenance during the life of the incubator. If, however, the cooling system fails to perform according to expectation, perform the following steps:

1. Check that the incubator has been set to the desired cooling mode. For the cooling system to operate, either COOL or AMBIENT mode must be selected.
2. Check that the circulation fans are operating. If either fan (internal or external fan) is not rotating when COOL or AMBIENT mode is engaged, and there are no obvious obstructions, contact your authorized service engineer for assistance.
3. If the temperature inside the chamber drops below 5 °C while the cooling system is operating, frost may form on the heat sink fins, reducing airflow and adversely affecting performance. Raise the temperature in the chamber to no less than 5 °C to avoid loss of performance.
4. Check that the rear fan inlet and outlets are not blocked and that there is sufficient clearance of 50 mm (2 in) between the rear of the incubator and the nearest possible obstruction.

### 12.2 BMS relay contact alarm

The BMS (Building Management System) Relay Contact Alarm allows a signal from a central alarm system to be switched ON or OFF to indicate an alarm condition at the incubator.

The following alarm conditions will activate the system: over-temperature, under-temperature, system failure, CO<sub>2</sub> high and CO<sub>2</sub> low.

As an integral option, the alarm can be programmed to indicate when the power fails (perhaps due to an electrical fault) or is switched off. If the power failure warning is active, the relay contacts will be reversed (pin 4, which is normally open, becomes normally closed and pin 6, which is normally closed, becomes normally open). The alarm will also respond to other types of alarms, depending on the options installed on the incubator.

The system is connected at the rear of the incubator via a standard 6-pin DIN socket (see Fig. 12-1 on p. 67) for location. The matching plug is provided, when the option is installed.

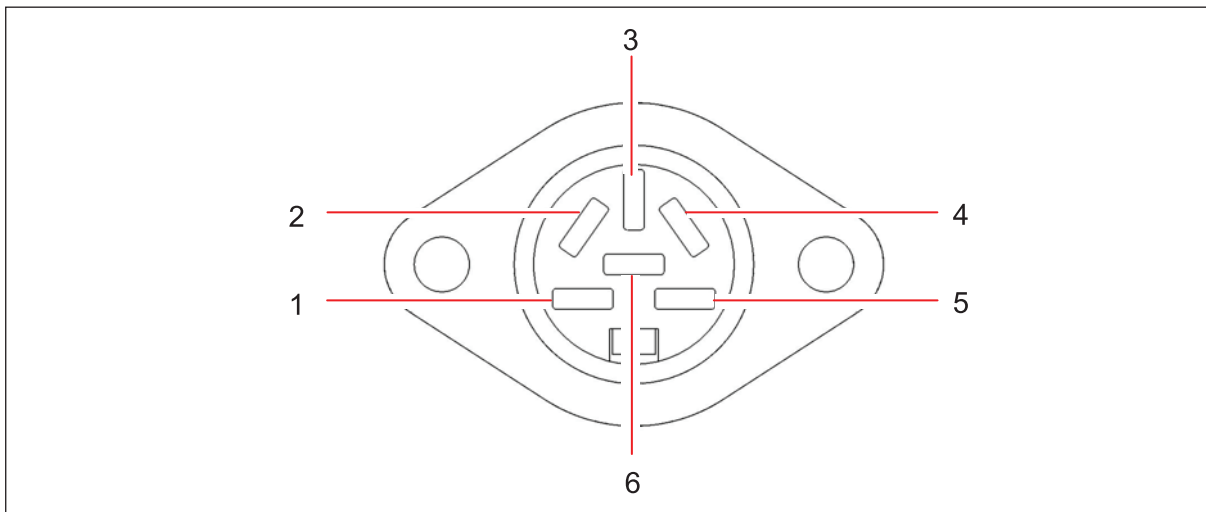

Fig. 12-1: BMS relay contact alarm socket

Pin	Designation	
1	24 V DC unregulated (170 R Models) 12 V DC unregulated (170 S Models)	To power external equipment such as a remote buzzer or light (100 mA maximum current available).*
2	0 V	
3	5 V DC	Via 10 K $\Omega$ pull-up resistor, for a logic signal to directly control an auxiliary control system.*
4	Normally closed	To access the relay contacts. Contact limits are 3 Amps @ 24 V DC and 3 Amps @ 34 V AC.
5	Common	
6	Normally open	

\*Cable length should not exceed 3 m (9.8 ft) to comply with EMC requirements.

The default setting for the alarm system is ON. To deactivate the relay using the incubator keypad:

1. Press USER.
2. Select BMS ALARM RELAY.
3. Select MAKE ALARM RELAY ACTIVE YES/NO.
4. Toggle to NO and then press ENTER.

The default setting for the power failure warning is ON. To make the alarm system ignore any power outage:

1. Press USER.
2. Select BMS ALARM RELAY.
3. Select MAKE ALARM RELAY ACTIVE AT POWER SWITCH OFF/FAILURE YES/NO.
4. Toggle to NO and then press ENTER.

## Equipment options

Galaxy® 170 R/170 S CO<sub>2</sub> Incubators  
English (EN)

### 12.3 High temperature disinfection

The High Temperature Disinfection option is designed to heat the internal chamber to 120 °C, maintain that temperature for 4 hours, and then allow the chamber to cool down to 37 °C or to the programmed temperature (if different from 37 °C) when normal control takes over. The cycle is designed to disinfect all internal surfaces and components, with the exception of the Oxygen control sensor where supplied.

#### 12.3.1 Using the high temperature disinfection (Galaxy R)

##### Prerequisites

- The incubator should be cleaned, disinfected, and dried thoroughly before starting the cycle, (see *Disinfection/Decontamination on p. 53*).
- The black protective cover must be removed (the white porous cover can remain in place).
- The shelves, shelf racks, humidity tray and silicone rubber feet and sleeves should all be in place during the cycle.
- The incubator **MUST** be clean and dry.
- The humidity tray **MUST** be empty, clean and dry.



#### **WARNING! Risk of personal injury**

Burns due to hot surface.

- ▶ Do not touch the equipment during the high temperature disinfection cycle.
- ▶ Do not open equipment door during the cycle.



#### **NOTICE! Risk of material damage**

- ▶ To avoid possible damage to the CO<sub>2</sub> sensor, never leave water in the humidity tray while the incubator is switched off, or when a high temperature disinfection cycle is initiated (optional feature).
- ▶ Allow a clearance of 50 mm (2 in) to allow access for oxygen sensor (if installed) removal.

1. Press the **USER** menu button, select **DISINFECTION** and press **START**. The incubator will then prompt: *IS CHAMBER CLEAN & DRY?* Answer **YES** if it is clean and dry.

The cycle will start automatically, unless the incubator is fitted with Oxygen Control, in which case the incubator will also prompt: *IS O<sub>2</sub> SENSOR REMOVED?* Ensure that the O<sub>2</sub> sensor has been removed and answer **YES** to begin the cycle, (see *High temperature disinfection option with oxygen control on p. 71*)

2. To cancel the cycle, press **CANCEL**. The incubator will cool down to the programmed level where normal control takes over.



If a Auto-Zero is scheduled to begin prior to a disinfection cycle, the Auto-Zero will abort until the cycle is complete. A user initiated Auto-Zero will also abort but will not resume after completion of the disinfection cycle.

3. If the incubator door is opened during a disinfection cycle, the process will continue as normal, a failure message will occur due to low temperature.



Certain areas of the glass door and inner door seal surface temperatures will be  $\pm 5$  °C of 120 °C.

4. After completion of the process, one of the following status messages will be displayed. If the cycle:



was completed successfully, *DISINFECTION COMPLETED OK* is shown.

was cancelled by the user, *DISINFECTION WAS ABORTED* is shown.

failed for any reason, *DISINFECTION FAILED [CODE: XX]* is shown.

The following tables lists the disinfection failure codes and descriptions, (see Tab. on p. 69) and (see Tab. on p. 69). If this happens, note the failure code and contact your service representative for advice.

**Disinfection failure codes and descriptions**

Failure Code	Failure Code Description (see Tab. on p. 69)
01	Z
02	W
03	W, Z
04	X
05	X, Z
06	W, X
07	W, X, Z
08	Y
09	Y, Z
0A	W, Y
0B	W, Y, Z
0C	X, Y
0D	X, Y, Z
0E	W, X, Y
0F	W, X, Y, Z

**Disinfection failure code explanations**

Failure Code Description	Explanation
W	Temperature drop during warm-up period: indicates the temperature fell more than 2 °C during the heating phase over a 60-second period.
X	Temperature drop during 4-hour period: indicates the temperature fell below 118.0 °C during the disinfection phase.
Y	Temperature increase during cool-down phase: indicates the temperature rose by more than 2 °C during the cooling phase over a 60-second period.
Z	Cancel key pressed.



- If the incubator power is cycled OFF then ON during a disinfection cycle due to a power outage, the incubator will power up as normal. This condition will be indicated by the absence of a completed disinfection status message (*DISINFECTION COMPLETED OK*).
- If the chamber temperature is above the setpoint or the element temperature is greater than a factory-preset control point, cool down will be entered until these conditions are satisfied.
- It is recommended that the Auto-Zero function be run following each disinfection cycle.

## Equipment options

Galaxy® 170 R/170 S CO<sub>2</sub> Incubators  
English (EN)

### 12.3.2 Using the high temperature disinfection (Galaxy S)

#### Prerequisites

- The incubator should be cleaned, disinfected, and dried thoroughly before starting the cycle, (see *Disinfection/Decontamination on p. 53*).
- The black protective cover must be removed (the white porous cover can remain in place).
- The shelves, shelf racks, humidity tray and silicone rubber feet and sleeves should all be in place during the cycle.
- The incubator **MUST** be clean and dry.
- The humidity tray **MUST** be empty, clean and dry.



#### **WARNING! Risk of personal injury**

Burns due to hot surface.

- ▶ Do not touch the equipment during the high temperature disinfection cycle.
- ▶ Do not open equipment door during the cycle.



#### **NOTICE! Risk of material damage**

- ▶ To avoid possible damage to the CO<sub>2</sub> sensor, never leave water in the humidity tray while the incubator is switched off, or when a high temperature disinfection cycle is initiated (optional feature).
- ▶ Allow a clearance of 50 mm (2 in) to allow access for oxygen sensor (if installed) removal.

1. Simultaneously press the ▼ and \* keys.

The display will change and the following prompt will appear: *HOT. DECON CYC.LE ENT.ER STA.RTS.*

2. Press the **enter** key to begin the cycle (or press the \* key to cancel the operation). The **enter** key command will only be accepted when the entire message has been displayed at least once.

When the disinfection cycle starts, the display will show another prompt: *IS INS.IDE CLE.AN AND.DRY.*

3. Press the **enter** key again (or press the \* key to cancel the operation). The **enter** key command will only be accepted when the entire message has been displayed at least once.

During the three stages of the disinfection cycle, the display keeps the user informed by scrolling through a sequence of messages as shown below:

- Current chamber temperature (in C) and time remaining (hours and minutes) are indicated as *120.2.45* (i.e., 120 °C with 2 hours and 45 minutes remaining).
- Every 10 seconds, by flashing one of the following messages for one second, the display will indicate which disinfection stage the incubator is in:
  - *HE.AT* (heating to 120 °C)
  - *DEC.ON* (maintaining 120 °C)
  - *CO.OL* (cool down).
- The time displayed counts up during the heat and cool stages, but it counts down from 4 hours during the disinfection stage. After the cool down phase is completed, the following messages will be displayed depending on the outcome:
  - *DEC.ON PAS.SED*

- *DEC.ON FAI.LED*
- If the message says that disinfection failed, it will be followed by any combination of the following messages:
  - *FAL.L DUR.ING HEA.T* (this indicates that the temperature dropped more than 2 °C over a 60-second period during the heating phase)
  - *FAL.L DUR.ING DEC.ON* (this indicates that the temperature fell below 118.0 °C during the disinfection phase)
  - *RIS.E DUR.ING COO.L* (this indicates that the temperature rose more than 2 °C over a 60-second period during the cool down phase)
  - *CAN.CEL BUT.TON PRE.SS* (this indicates that the CANCEL button was pressed during the heating or disinfection phase)

If more than one of the above-mentioned events occurred, the messages will be displayed consecutively in the sequence in which the events occurred.

The disinfection cycle can be cancelled at any time by pressing the \* key.

If the chamber temperature rises above setpoint or the element temperature is greater than the total of chamber setpoint + chamber low control point temperature, the system will automatically begin cool down until these conditions are satisfied.

If the incubator door is opened—a procedure that is highly discouraged because of the dangerously high temperature inside the chamber—during a disinfection cycle, the process will continue as normal. A failure message will, however, appear if the temperature falls as a result of the door opening during either the heating phase or the disinfection phase.

If the incubator power is cycled OFF then ON, the incubator will power up as normal. This condition will be indicated by an absence of a completed disinfection status message (either *DEC.ON PAS.SED* or *DEC.ON FAI.LED*)

If the chamber temperature is above 65 °C, the display will read 65.0 until the temperature drops below 65, and a °C.F.AIL alarm will occur since the control system cannot measure temperatures above 65 °C in normal mode.

### 12.3.3 High temperature disinfection option with oxygen control



#### **NOTICE! Risk of material damage**

- ▶ To avoid possible damage to the CO<sub>2</sub> sensor, never leave water in the humidity tray while the incubator is switched off, or when a high temperature disinfection cycle is initiated (optional feature).
  - ▶ Allow a clearance of 50 mm (2 in) to allow access for oxygen sensor (if installed) removal.
- 

The Oxygen Sensor is an electrochemical device that will be destroyed by the high temperature used to disinfect the incubator if left in place. For this reason, the Oxygen Sensor must be removed from the incubator prior to a High Temperature Disinfection Cycle. The sensor can be accessed from the rear panel of the incubator.

**Equipment options**

Galaxy® 170 R/170 S CO<sub>2</sub> Incubators  
English (EN)

Detailed removal and installation instructions are provided (see *Removing and replacing O<sub>2</sub> sensor on p. 76*).

## 12.4 O<sub>2</sub> control (1 - 19 %) (Galaxy R only)

This oxygen control option is designed to cover the 1 - 19 % range by adding nitrogen to bring the level below ambient. If you have the 0.1 - 19 % oxygen control option, (see *O<sub>2</sub> control (0.1 - 19 %) (Galaxy R only) on p. 80*); or if you have the 1 - 95 % oxygen control option, (see *O<sub>2</sub> control (1 - 95 %) (Galaxy R only) on p. 83*).

### 12.4.1 Setting up the N<sub>2</sub> tank

#### Prerequisites

Before you set up your oxygen control, ensure that you have the proper equipment for your nitrogen supply:

- 2 cylinders of nitrogen, regulation size W
- 1 two-stage pressure regulator
- 1 Inline pressure regulator
- 6 mm PVC tubing
- tubing clips

Set up the nitrogen tanks as follows:

1. Inspect them to ensure there are no leaks or other damage.
2. Check that the two-stage pressure regulator valve and the inline pressure regulator valve are closed by trying to turn their knobs in a counter-clockwise direction; the knobs should be at the stop point.
3. Place the inline pressure regulator close to the incubator.
4. Securely attach the two-stage pressure regulator to the nitrogen tank's outlet and to the inline pressure regulator's inlet with tubing, securing both ends with clips.
5. Connect the inline pressure regulator's outlet to the incubator's N<sub>2</sub> inlet on the right side of the control box at the rear of the incubator (see Fig. 2-3 on p. 11); secure both ends with clips.
6. Proceed as indicated in (see *Setting up oxygen control on p. 72*).



To add an automatic gas cylinder changeover instrument: with the incubator turned off, connect its inlet to the two-stage pressure regulator's outlet, and the changeover instrument's outlet to the inline pressure regulator's inlet with tubing, securing the ends with tubing clips.

### 12.4.2 Setting up oxygen control

1. Remove the black plastic protective cover from the hydrophobic filter cap (making sure that the hydrophobic filter cap is not removed with it), located in the rear wall of the incubator chamber. Retain the cover for use when you clean the chamber.
2. Open the nitrogen gas supply from the tank. Set the N<sub>2</sub> tank's outlet pressure gauge to 1.5 bar.
3. Set the nitrogen regulator to 14.5 PSI (1 bar). The nitrogen will be fed into the incubator through a filter that is already installed in the gas line. The gas flow rate is approximately 20 liters/minute.

**i** If the programmed O<sub>2</sub> level is close to the ambient oxygen, it may be necessary to reduce the cylinder pressure below 1 bar to stop the oxygen level from undershooting the programmed value.

Both inner and outer doors must be open.

4. After the incubator has been humidified and left overnight to stabilize, select the **USER** menu; then, using the ▲ or ▼ direction key, select **OXYGEN SENSOR-REF TO ATMOSPHERE** (see Fig. 12-2 on p. 73) and follow the onscreen instructions to automatically calibrate the oxygen sensor to atmospheric oxygen levels. The oxygen reading is automatically adjusted to 19.7 %, which is the true reading taking into account the relative humidity level.

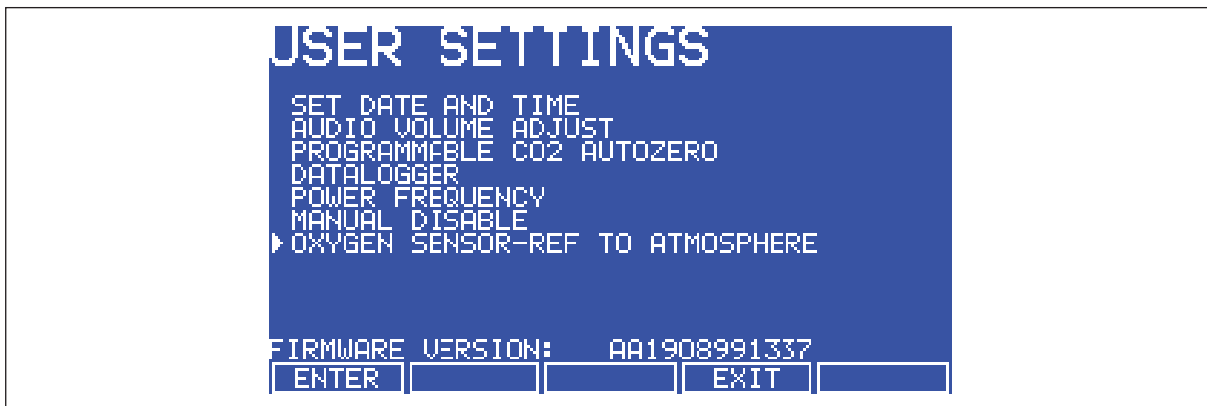

Fig. 12-2: Selecting OXYGEN SENSOR-REF TO ATMOSPHERE

5. Enable the oxygen control: (a) press the **USER** function key, (b) using the ▲ or ▼ direction key, select **MANUAL DISABLE** (see Fig. 12-3 on p. 73), (c) press the **ENTER** function key, (d) select **ENABLE** for Oxygen Control using the ◀ or ▶ direction key, then (e) press the **ENTER** function key.

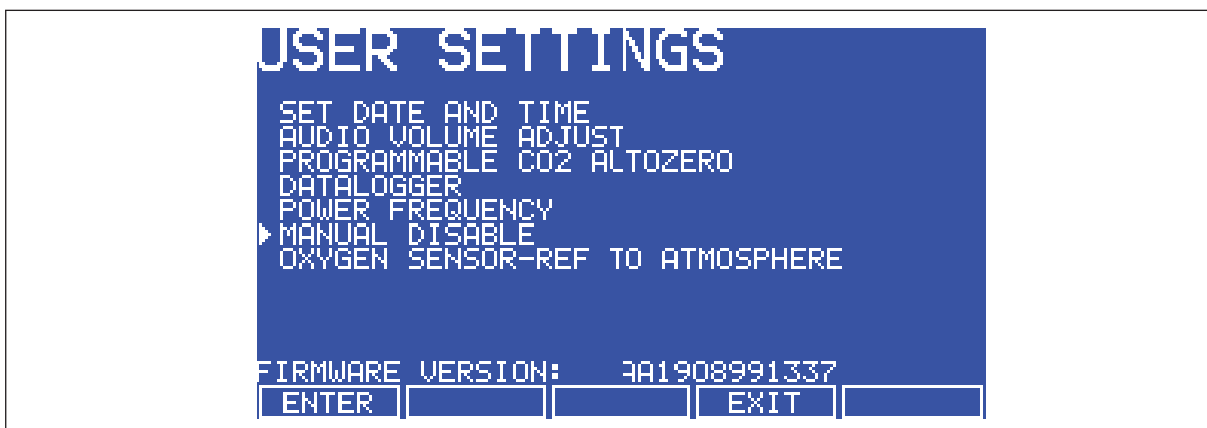

Fig. 12-3: USER SETTINGS Screen

6. Navigate to the **PROG** screen to set the required Oxygen level.
7. The Alarm levels are automatically set to ± 0.5 % above or below the programmed value, but you can modify them in the **ALARM** screen. Re-arming the alarm can be delayed until the programmed value is achieved: select the relevant option in the **ALARM** screen.

**Equipment options**

Galaxy® 170 R/170 S CO<sub>2</sub> Incubators  
English (EN)



At low oxygen levels, the CO<sub>2</sub> and O<sub>2</sub> levels may not have fully recovered within the Alarm limits after the 15-minute “Delay in arming after door opening.” This time period can be increased (in the ALARM screen) to suit individual circumstances.

8. By controlling the Duty Cycle of the N<sub>2</sub> valve, Oxygen Control can be tailored to achieve programmed Oxygen and Carbon Dioxide levels at approximately the same time.

### 12.4.3 Operating guidelines

We recommend that you repeat the **OXYGEN SENSOR-REF TO ATMOSPHERE** procedure (see *Setting up the N<sub>2</sub> tank on p. 72*) Step 3, and further details (see *Referencing to atmosphere on p. 74*) once a month to ensure that any long-term drift in sensor output will be corrected. Be sure to do it at the chamber operating temperature.

When you are cleaning the chamber, be very careful not to wet the oxygen sensor or CO<sub>2</sub> sensor. Never use solvents on the sensor membrane; rather, be sure to cap the hydrophobic filter before you clean. It is good practice to replace the filter each time you clean the incubator chamber, to avoid the possibility of filter contamination.

Under normal relative humidity conditions (95 - 99 %), the oxygen sensor's performance should not be affected. If, however, liquid condenses around the sensor, gas flow may become restricted, giving the sensor a low signal. This may occur if there is a large liquid spill inside the chamber or if the incubator is turned off while it is fully humidified. Should such condensation appear, normal operation can be restored by:

- removing the humidity tray,
- drying the chamber completely,
- and then running the incubator at 37 °C for one hour.

This will dry out the sensor(s). The humidity tray can then be reinstalled and the incubator can be safely re-humidified.

### 12.4.4 Referencing to atmosphere

The oxygen sensor is a self-powered electrochemical cell that has a finite life dependent on the ambient oxygen level. A typical lifespan is 1 - 2 years at atmospheric levels. During the sensor's lifespan, the signal produced will slowly degrade until it is ultimately unusable. For this reason, we recommend that you reference the sensor to atmospheric oxygen levels on a monthly basis.

The **OXYGEN SENSOR-REF TO ATMOSPHERE** procedure has three possible outcomes. The first is that the procedure was completely successful, and no further action need be taken until the following month's test. The second and third outcomes are presented in detail in (see *Replace sensor soon on p. 75*) and (see *Replace sensor now on p. 75*).

For instructions on removing and replacing the sensor (see *Removing and replacing O<sub>2</sub> sensor on p. 76*).

#### 12.4.5 Replace sensor soon

If the referencing procedure was successful but the sensor is nearing the end of its working life, the following message will appear in the display:

*O<sub>2</sub> REFERENCE OK BUT SENSOR REQUIRES REPLACEMENT SHORTLY*

*PRESS ENTER TO PROCEED*

When you press the **ENTER** function key, the message will change to this:

*O<sub>2</sub> SENSOR*

*THE RESULT OF THE O<sub>2</sub> REFERENCE PROCESS SHOWS THAT THE SIGNAL FROM THE O<sub>2</sub> SENSOR HAS REDUCED INDICATING IT IS APPROACHING THE END OF ITS LIFE.*

*REPEAT THE REFERENCE PROCEDURE TO CONFIRM THIS RESULT.*

*PRESS ENTER TO PROCEED.*

Press the **ENTER** function key.

#### 12.4.6 Replace sensor now

If the referencing procedure failed, Oxygen Control will be disabled. The incubator will appear to be functioning as normal until a new sensor is installed and referenced to atmospheric level. The following message will appear in the display:

*O<sub>2</sub> REFERENCE FAILED*

*PRESS ENTER TO PROCEED*

When you press the **ENTER** function key, the message will change to this:

*O<sub>2</sub> SENSOR*

*THE RESULT OF THE O<sub>2</sub> REFERENCE PROCESS SHOWS THAT THE SIGNAL FROM THE O<sub>2</sub> SENSOR HAS REDUCED BELOW AN ACCEPTABLE LEVEL AND HAS REACHED THE END OF ITS LIFE.*

*REPEAT THE REFERENCE PROCEDURE TO CONFIRM THIS RESULT.*

*PRESS NEXT TO PROCEED.*

When you press the **NEXT** function key, the message will change to this:

*O<sub>2</sub> SENSOR*

**Equipment options**

Galaxy® 170 R/170 S CO<sub>2</sub> Incubators  
English (EN)

*OXYGEN CONTROL HAS BEEN DISABLED AS A RESULT BUT THE INCUBATOR IS OTHERWISE FULLY OPERATIONAL.*

*PRESS PREV TO VIEW PREVIOUS SCREEN. PRESS EXIT TO EXIT.*

When you press the **EXIT** function key, you will return to the **USER** screen and normal operation.

### 12.4.7 Removing and replacing O<sub>2</sub> sensor

#### Prerequisites

- Oxygen sensor removal tool (see Fig. 12-5 on p. 77)

**NOTICE! Risk of material damage**

- ▶ Grasp white connector body when disconnection wire leads.
- ▶ Do not pull on wire leads.

1. Pull the rear access cover (see Fig. 12-4 on p. 76) off the rear outside wall of the incubator to gain access to the oxygen sensor.

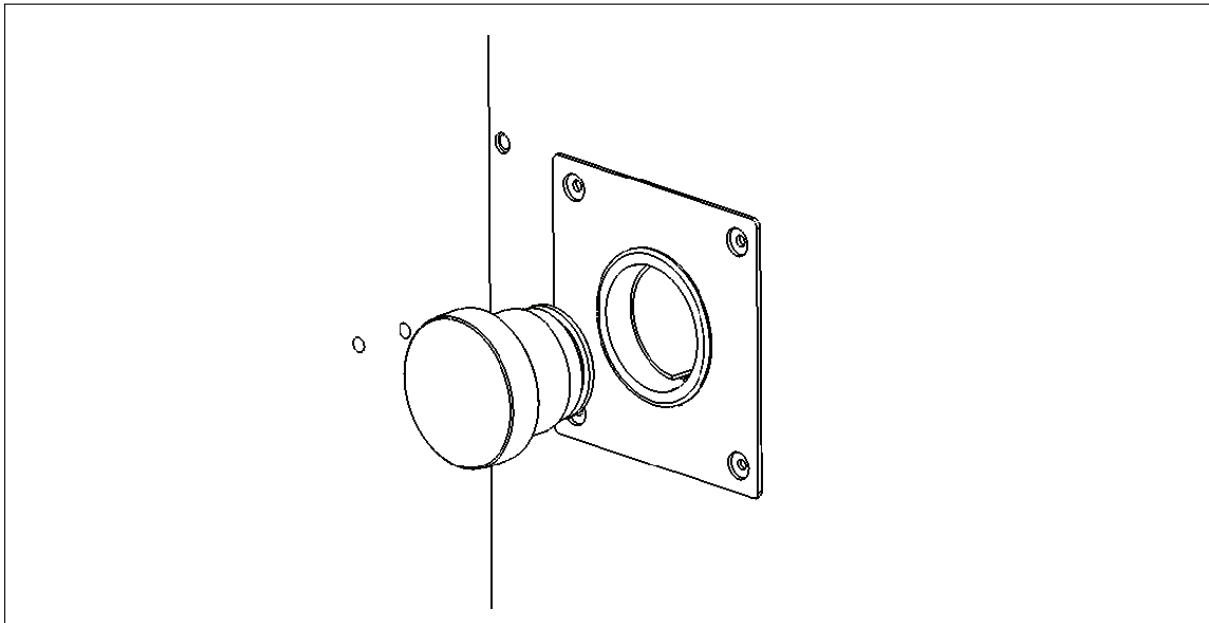

Fig. 12-4: Oxygen sensor rear access cover

2. Reach inside and disconnect the sensor by unplugging the connector: be sure to grasp the white connector body.
3. Using the sensor removal tool (see Fig. 12-5 on p. 77), unscrew the oxygen sensor by turning it counter-clockwise. Because the oxygen sensor contains lead, be sure to dispose of it according to local regulations.



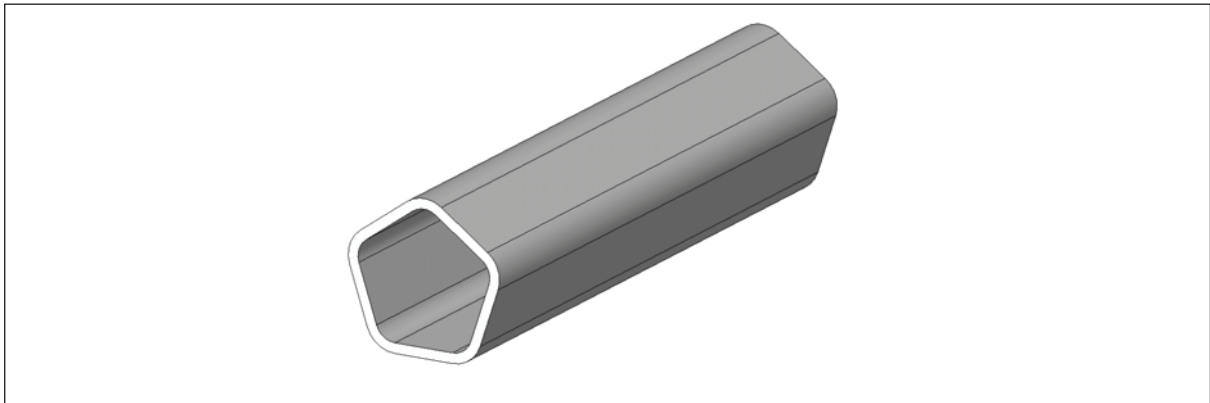

Fig. 12-5: Oxygen sensor removal tool

4. Using the sensor removal tool, install the new oxygen sensor by turning it clockwise until it is finger-tight. Do not use excessive force or any metal tool.
5. Reconnect the sensor by plugging the white connector body back in.
6. Make sure that the sensor wires are inside the metal sensor tube to protect them from damage, then press the rear access cover snugly back in place.
7. After replacing the sensor, humidify the incubator and allow it to stabilize overnight.
8. Calibrate the sensor with reference to the atmospheric oxygen level (see *Referencing to atmosphere on p. 74*).

#### 12.4.8 Replacing the filter disc

The hydrophobic filter installed on your Oxygen Control system helps prevent condensation from reaching the sensor (see Fig. 12-6 on p. 78).

##### 12.4.8.1 To replace the hydrophobic filter disc (membrane)

1. Carefully pull the complete hydrophobic filter holder away from the oxygen sensor holder on the rear wall of the chamber.
2. With a fingertip or a 10 - 11 mm (½ in) rod, from the rear of the filter holder, gently push the filter membrane disc and the filter cap out of the holder.
3. Clean and dry the filter holder and cap.
4. Wearing gloves to avoid contaminating the filter disc, gently place the new filter membrane disc into the filter holder recess. The filter disc works in both directions, so there is no right or wrong side.

**Equipment options**

Galaxy® 170 R/170 S CO<sub>2</sub> Incubators  
English (EN)

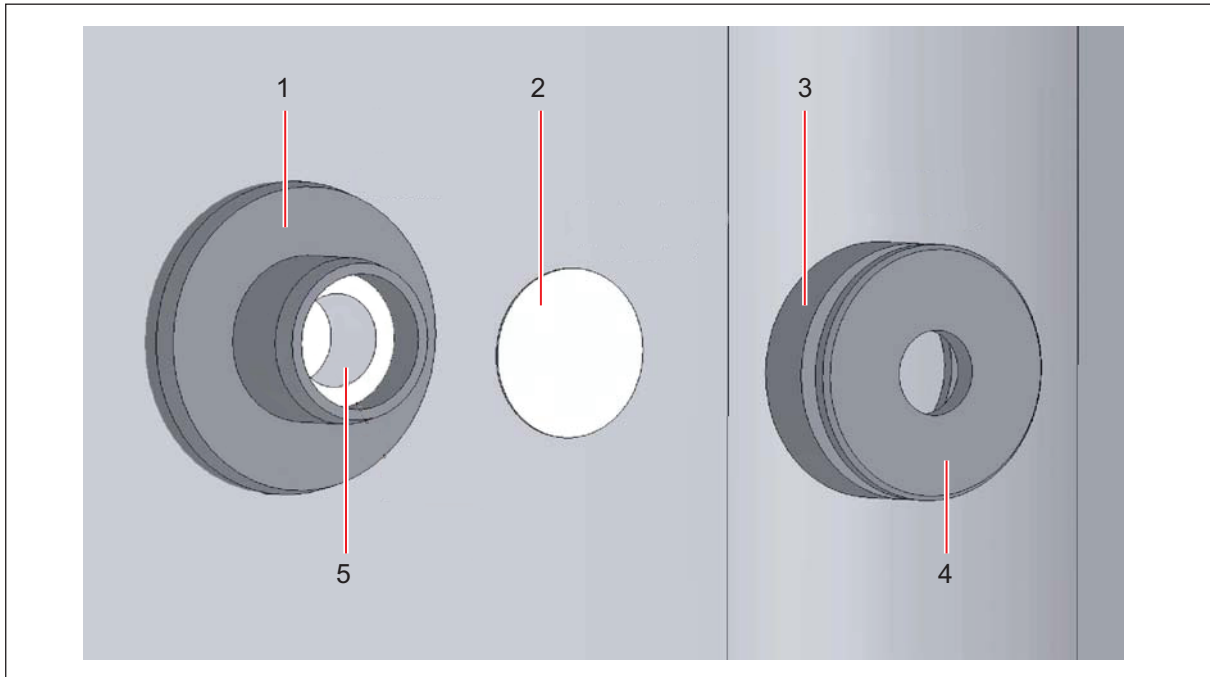

Fig. 12-6: Hydrophobic filter and holder assembly (exploded view)

- |                                    |                                 |
|------------------------------------|---------------------------------|
| <b>1 Oxygen sensor holder</b>      | <b>4 Hydrophobic filter cap</b> |
| <b>2 Hydrophobic filter disc</b>   | <b>5 Oxygen sensor</b>          |
| <b>3 Hydrophobic filter holder</b> |                                 |

5. Make sure the O-rings (between the cap & filter holder and between the filter holder & oxygen sensor holder) are undamaged and securely in place.
6. Gently press the filter cap back in.
7. Press fit the filter assembly back onto the oxygen sensor holder.

#### 12.4.9 Troubleshooting the O<sub>2</sub> sensor

If the oxygen sensor fails suddenly, it is very likely that the sensor inlet membrane has become blocked by condensation. This can be seen on the **DATALOGGER** screen as a sudden drop from the programmed value to nearly zero.

To dry the membrane:

1. Remove the hydrophobic filter holder assembly (see Fig. 12-4 on p. 76) by unscrewing it (counter-clockwise).
2. Program the incubator for a temperature of at least 37 °C (or higher if you normally operate the incubator at a higher temperature).
3. Close the door and allow the temperature to recover.

4. Reopen the door for 15 seconds to release any build-up of humidity.
5. Repeat steps 3 and 4 every 30 minutes while monitoring the **DATALOGGER O<sub>2</sub>** Graph. The oxygen level should recover after a few hours.
6. Leave the incubator for a few more hours to be ensure that the sensor membrane has thoroughly dried out.
7. Replace the hydrophobic filter disc (see *Replacing the filter disc on p. 77*).
8. Re-humidify the incubator.
9. After 2 to 3 hours, carry out an **OXYGEN SENSOR-REF TO ATMOSPHERE** (see *Referencing to atmosphere on p. 74*). When the referencing has been successfully completed, the incubator is ready for use.

#### 12.4.10 Specifications

The Oxygen Control option has the following characteristics:

Sensor Type	Self-powered, diffusion-limited, electrochemical cell with temperature compensation.
Zero Signal in Nitrogen	< 50 $\mu$ V
Temperature Compensation	$\pm$ 2 % of signal variation from 0 - 40 °C
Relative Humidity Range	0 - 99 %, non-condensing
Operating Temperature Range	-20 °C to + 50 °C
Resolution	0.01 % Oxygen
Expected Operating Life	1 - 2 years in ambient oxygen
Hydrophobic Filter Operating Life	No data available on the filter lifespan but we are confident to expect it will last at least 6 months.
Nitrogen Input Rate	20 L/min at 14.5 PSI (1 bar)
Typical Oxygen Reduction Rates	3 minutes to 16 % 4 minutes to 11 % 8 minutes to 6 %

**Equipment options**

Galaxy® 170 R/170 S CO<sub>2</sub> Incubators  
English (EN)

## 12.5 O<sub>2</sub> control (0.1 - 19 %) (Galaxy R only)

This oxygen control option uses the controlled addition of nitrogen to reduce the oxygen level below ambient. If you have the 1 - 19 % oxygen control option, (see *O<sub>2</sub> control (1 - 19 %) (Galaxy R only)* on p. 72); or if you have the 1 - 95 % oxygen control option, (see *O<sub>2</sub> control (1 - 95 %) (Galaxy R only)* on p. 83).



The O<sub>2</sub> sensor must be calibrated when used to achieve O<sub>2</sub> control below 1 %. For calibration instructions, refer to M1306-0051, Galaxy® O<sub>2</sub> Sensor Setup Instructions manual.

You will need an oxygen sensor zeroing kit to perform the calibration. Contact Eppendorf sales for ordering information.

### 12.5.1 Setting up the N<sub>2</sub> tank

#### Prerequisites

Before you set up your oxygen control, ensure that you have the proper equipment for your nitrogen supply:

- 2 cylinders of nitrogen, regulation size W
- 1 two-stage pressure regulator
- 1 Inline pressure regulator
- 6 mm PVC tubing
- tubing clips

Set up the nitrogen tanks as follows:

1. Inspect them to ensure there are no leaks or other damage.
2. Check that the two-stage pressure regulator valve and the inline pressure regulator valve are closed by trying to turn their knobs in a counter-clockwise direction; the knobs should be at the stop point.
3. Place the inline pressure regulator close to the incubator.
4. Securely attach the two-stage pressure regulator to the nitrogen tank's outlet and to the inline pressure regulator's inlet with tubing, securing both ends with clips.
5. Connect the inline pressure regulator's outlet to the incubator's N<sub>2</sub> inlet on the right side of the control box at the rear of the incubator (see Fig. 2-3 on p. 11); secure both ends with clips.
6. Proceed as indicated in (see *Setting up O<sub>2</sub> control* on p. 80).



To add an automatic gas cylinder changeover instrument: with the incubator turned off, connect its inlet to the two-stage pressure regulator's outlet, and the changeover instrument's outlet to the inline pressure regulator's inlet with tubing, securing the ends with tubing clips.

### 12.5.2 Setting up O<sub>2</sub> control

Oxygen control is tailored such that both the O<sub>2</sub> and the CO<sub>2</sub> levels are achieved at approximately the same time, via control of the N<sub>2</sub> valve's duty cycle (but only within the range of 0.1 - 19 % O<sub>2</sub>).

1. Remove the black plastic protective cover (making sure that the hydrophobic filter cap is not removed with it) from the port inside the chamber. Retain the cover for use when you clean the chamber.
2. Open the nitrogen gas supply from the tank and set the N<sub>2</sub> tank's outlet pressure gauge to 1.5 bar.
3. Set the nitrogen regulator to 14.5 PSI (1 bar). The nitrogen will be fed into the incubator through a filter that is already installed in the gas line. The gas flow rate is approximately 20 liters/minute.



- If the programmed O<sub>2</sub> level is close to the ambient oxygen, it may be necessary to reduce the cylinder pressure below 1 bar to stop the oxygen level from undershooting the programmed value.
- When working at 0.1% O<sub>2</sub>, set the CO<sub>2</sub> pressure to 10 PSI (0.7 bar).

Be sure to humidify the incubator and leave it overnight to stabilize before proceeding further.

To automatically calibrate the sensor to atmospheric oxygen levels, select **OXYGEN SENSOR – REF TO ATMOSPHERE** in the **USER** menu, and then follow the onscreen instructions.

The oxygen reading is automatically adjusted to 19.7 %, which is the true reading taking into account the Relative Humidity in the chamber.

### 12.5.3 Enabling or disabling O<sub>2</sub> control

To enable oxygen control:

1. Select the **USER** screen by pressing the **USER** function key.
2. Use the direction keys to select **MANUAL DISABLE**.
3. Press the **ENTER** function key, then use the direction keys to select **ON** for Oxygen Control.
4. Press the **ENTER** function key again.

Program the required oxygen level in the **PROG** screen, following the onscreen instructions.

To disable oxygen control, follow the pattern used to enable it, but this time select **USER, MANUAL DISABLE, ENTER, OFF** and then **ENTER** again.

### 12.5.4 Alarms

The alarm levels are set automatically to  $\pm 0.5$  % above and below the programmed value, but these points can be altered in the **ALARM** screen. In addition, the re-arming of the alarm can be delayed until the Programmed Value is achieved by selecting the relevant option in the **ALARM** screen.

For example, it is possible at low oxygen levels that the CO<sub>2</sub> and O<sub>2</sub> levels might not fully recover within the Alarm Limits after the 15-minute **DELAY IN ARMING AFTER DOOR OPENING** period has elapsed, so this time period can be increased in the **ALARM** screen to suit individual circumstances.

### 12.5.5 Referencing to atmosphere

To reference the oxygen sensor to atmospheric oxygen levels, (see *Referencing to atmosphere on p. 74*).

**Equipment options**

Galaxy® 170 R/170 S CO<sub>2</sub> Incubators  
English (EN)

### 12.5.6 Programming desired O<sub>2</sub> level

Program the required oxygen level in the **PROG** screen, following the onscreen instructions.

If you are running an O<sub>2</sub> level programmed between 0.1 - 0.9 %, you should know that the control system is set to operate in the following way to minimize N<sub>2</sub> consumption after the glass door has been opened:

- The N<sub>2</sub> valve is switched on continuously until the O<sub>2</sub> level is within 0.1 % of setpoint.
- The CO<sub>2</sub> valve is then switched on to allow the CO<sub>2</sub> level to reach setpoint. If the O<sub>2</sub> level is above setpoint 15 minutes after the N<sub>2</sub> valve has been switched off, it is switched back on for 40 seconds and the CO<sub>2</sub> valve is switched on for 20 seconds. The CO<sub>2</sub> valve will then pulse until setpoint is reached.
- The process described above will repeat itself until the O<sub>2</sub> setpoint is reached.
- The same process will also repeat if the O<sub>2</sub> level rises above setpoint, and if the O<sub>2</sub> level should rise toward 0.2 % above setpoint, the N<sub>2</sub> valve will open again continuously until the O<sub>2</sub> level returns to setpoint.
- The CO<sub>2</sub> Auto-Zero, which would normally take place after a CO<sub>2</sub> alarm, will be cancelled to avoid the introduction of additional O<sub>2</sub> into the chamber. For the same reason, we recommend canceling the programmed CO<sub>2</sub> Auto-Zero.

### 12.5.7 Precautions

Under normal humidity conditions (95 - 99 % RH), the sensor is unaffected. If for any reason (such as a large spill inside the chamber or the incubator being switched off while fully humidified) liquid condenses around the sensor, the result may be restriction of gas flow and a low sensor signal. Should such condensation appear on the chamber walls, normal operation can be easily restored by removing the humidity tray, drying the chamber completely, and then running the incubator at 37 °C for one hour. This will dry out the sensor. After the hour has elapsed, the humidity tray can be reinstalled and the incubator humidified again.

## 12.6 O<sub>2</sub> control (1 - 95 %) (Galaxy R only)

This oxygen control option uses the controlled addition of oxygen to increase the level above ambient and the controlled addition of nitrogen to reduce the oxygen level below ambient. If you have the 1 - 19 % oxygen control option, (see *O<sub>2</sub> control (1 - 19 %) (Galaxy R only) on p. 72*); or for the 0.1 - 19 % oxygen control option, (see *O<sub>2</sub> control (0.1 - 19 %) (Galaxy R only) on p. 80*).



### **WARNING! Risk of personal injury**

High oxygen levels inside the chamber require additional safety precautions:

- ▶ Setting the oxygen to levels > 24 % can greatly increase the chance of fire and explosion. Operators planning to set oxygen at 24 - 95 % should therefore take all appropriate precautions to minimize the risk. Eppendorf does not recommend using external (heat-generating) equipment inside the chamber when oxygen conditions will be > 24 %.
- ▶ Before opening the incubator door, make sure no flames (Bunsen burner, etc.) are in the vicinity.
- ▶ Avoid the presence of other combustible gases (hydrogen, methane, etc.)
- ▶ Ensure that all solenoid valves and pressure regulators and gauges controlling the gas supply are grease-free for use with oxygen.

If your incubator is operating in the 3 - 95 % range of O<sub>2</sub> control, only the N<sub>2</sub> valve will operate for setpoints below 19 %; both the N<sub>2</sub> and O<sub>2</sub> valves will operate for setpoints between 19 and 80 %; and for setpoints above 80 %, only the O<sub>2</sub> valve will operate.



If you plan to maintain O<sub>2</sub> levels of 80 - 95 %, (see *Important notes for O<sub>2</sub> levels > 80 % on p. 85*).

### 12.6.1 Setting up the N<sub>2</sub> tank

#### Prerequisites

Before you set up your oxygen control, ensure that you have the proper equipment for your nitrogen supply:

- 2 cylinders of nitrogen, regulation size W
- 1 two-stage pressure regulator
- 1 Inline pressure regulator
- 6 mm PVC tubing
- tubing clips

Set up the nitrogen tanks as follows:

1. Inspect them to ensure there are no leaks or other damage.
2. Check that the two-stage pressure regulator valve and the inline pressure regulator valve are closed by trying to turn their knobs in a counter-clockwise direction; the knobs should be at the stop point.
3. Place the inline pressure regulator close to the incubator.

## Equipment options

Galaxy® 170 R/170 S CO<sub>2</sub> Incubators  
English (EN)

4. Securely attach the two-stage pressure regulator to the nitrogen tank's outlet and to the inline pressure regulator's inlet with tubing, securing both ends with clips.
5. Connect the inline pressure regulator's outlet to the incubator's N<sub>2</sub> inlet on the right side of the control box at the rear of the incubator (see Fig. 2-3 on p. 11); secure both ends with clips.
6. Proceed as indicated in (see *Setting up O<sub>2</sub> control on p. 84*).



To add an automatic gas cylinder changeover instrument: with the incubator turned off, connect its inlet to the two-stage pressure regulator's outlet, and the changeover instrument's outlet to the inline pressure regulator's inlet with tubing, securing the ends with tubing clips.

### 12.6.2 Setting up O<sub>2</sub> control

Oxygen control is tailored such that both the O<sub>2</sub> and the CO<sub>2</sub> levels are achieved at approximately the same time, via control of the O<sub>2</sub> or N<sub>2</sub> valve's duty cycle.

1. Remove the black plastic protective cover (making sure that the hydrophobic filter cap is not removed with it) from the port inside the chamber. Retain the cover for use when you clean the chamber.
2. Open the nitrogen gas supply from the tank and set the N<sub>2</sub> tank's outlet pressure gauge to 1.5 bar.
3. Set the nitrogen regulator to 14.5 PSI (1 bar). The nitrogen will be fed into the incubator through a filter that is already installed in the gas line. The gas flow rate is approximately 20 liters/minute.



If the programmed O<sub>2</sub> level is close to the ambient oxygen, it may be necessary to reduce the cylinder pressure below 1 bar to stop the oxygen level from undershooting the programmed value.

4. Install the oxygen cylinder in the same manner as outlined for the nitrogen cylinder installation (see *Setting up the N<sub>2</sub> tank on p. 83*), using the incubator's O<sub>2</sub> inlet, of course. For this application, you will need another two-stage pressure regulator and another inline pressure regulator.



Be sure to humidify the incubator and leave it overnight to stabilize before proceeding further.

To automatically calibrate the sensor to atmospheric oxygen levels, select **OXYGEN SENSOR – REF TO ATMOSPHERE** in the **USER** menu, and then follow the onscreen instructions.

The oxygen reading is automatically adjusted to 19.7 %, which is the true reading taking into account the Relative Humidity in the chamber.

### 12.6.3 Enabling or disabling O<sub>2</sub> control

To enable oxygen control:

1. Select the **USER** screen by pressing the **USER** function key.
2. Use the direction keys to select **MANUAL DISABLE**.
3. Press the **ENTER** function key, then use the direction keys to select **ON** for Oxygen Control.
4. Press the **ENTER** function key again.

Program the required oxygen level in the **PROG** screen, following the onscreen instructions.



To disable oxygen control, follow the pattern used to enable it, but this time select **USER, MANUAL DISABLE, ENTER, OFF** and then **ENTER** again.

#### 12.6.4 Important notes for O<sub>2</sub> levels > 80 %

If you are running the incubator with a dry chamber and no CO<sub>2</sub>, the recommended maximum O<sub>2</sub> level is 95 %. In addition, open samples inside the chamber can cause RH to increase, and the O<sub>2</sub> sensor may require recalibration to work properly in a completely dry atmosphere.

For a humidified chamber with no CO<sub>2</sub>, the recommended maximum O<sub>2</sub> level is 92 %, while for a humidified chamber with 5 % CO<sub>2</sub>, we recommend no more than 87 % O<sub>2</sub>.

When the incubator is running at normal humidity level (i.e., 95 % RH), there is approximately 6 % (by volume) water vapor present in the chamber. If 5 % CO<sub>2</sub> is also present, the maximum achievable level of O<sub>2</sub>—without using excessive quantities of oxygen—is approximately 87 %. Oxygen direct from a cylinder has a dewpoint temperature of < -45°C, corresponding to 0.06 % water vapor. As it enters the incubator, therefore, its temperature is very low and even as it is warmed, its RH level is very low. Both of these factors affect the performance of the O<sub>2</sub> detector. To minimize these effects, O<sub>2</sub> is fed continuously until it arrives at 0.4 % below setpoint. To allow the detector signal to recover and the RH level to build, there is a 3-minute delay. If O<sub>2</sub> is still required, it is fed in for 10 seconds, with an additional 3-minute delay until setpoint is achieved.

As the humidity level rises, the O<sub>2</sub> content in the chamber will diminish. The use of O<sub>2</sub> will rise considerably as the setpoint approaches the sum contents of water vapor and CO<sub>2</sub> in the chamber. In the short term, it is possible to achieve higher levels of O<sub>2</sub>, but as humidity rises and O<sub>2</sub> content is pushed down, there will be a continuous demand for O<sub>2</sub> and RH will remain too low. At the same time, as O<sub>2</sub> is pumped in, the CO<sub>2</sub> level will also diminish, causing the system to add CO<sub>2</sub>, which in turn causes the O<sub>2</sub> level to drop again.

If the O<sub>2</sub> setpoint is too high, the incubator can consume some 2,500 liters of O<sub>2</sub> per day—which does not include the extra oxygen consumed each time the door is opened (about 500 liters).

#### 12.6.5 Alarms

The alarm levels are set automatically to ± 0.5 % above and below the programmed value, but these points can be altered in the **ALARM** screen. In addition, the re-arming of the alarm can be delayed until the Programmed Value is achieved by selecting the relevant option in the **ALARM** screen.

For example, it is possible at low oxygen levels that the CO<sub>2</sub> and O<sub>2</sub> levels might not fully recover within the Alarm Limits after the 15-minute **DELAY IN ARMING AFTER DOOR OPENING** period has elapsed, so this time period can be increased in the **ALARM** screen to suit individual circumstances.

#### 12.6.6 Referencing to atmosphere



It is highly recommended to reference the sensor to atmospheric oxygen at least once per month.

**Equipment options**

Galaxy® 170 R/170 S CO<sub>2</sub> Incubators  
English (EN)

To reference the oxygen sensor to atmospheric oxygen levels, (see *Referencing to atmosphere* on p. 74).

### 12.6.7 Programming desired O<sub>2</sub> level

Program the required oxygen level in the **PROG** screen, following the onscreen instructions.

### 12.6.8 Other precautions

Under normal humidity conditions (95 - 99 % RH), the sensor is unaffected. If for any reason (such as a large spill inside the chamber or the incubator being switched off while fully humidified) liquid condenses around the sensor, the result may be restriction of gas flow and a low sensor signal. Should such condensation appear on the chamber walls, normal operation can be easily restored by removing the humidity tray, drying the chamber completely, and then running the incubator at 37 °C for one hour. This will dry out the sensor. After the hour has elapsed, the humidity tray can be reinstalled and the incubator humidified again.

For routine service checks of the sensor, (see *Troubleshooting the O<sub>2</sub> sensor* on p. 78).

### 12.6.9 Specifications

(see *Specifications* on p. 79).

## 12.7 O<sub>2</sub> Sensor replacement (Galaxy R only)

When the O<sub>2</sub> sensor needs to be replaced, (see *Removing and replacing O<sub>2</sub> sensor* on p. 76), or the Galaxy O<sub>2</sub> Sensor Setup, M1308-0051 manual for instructions.

## 12.8 IP66 sealed electrical outlet socket

The IP66 Sealed Electrical Outlet Socket is designed to provide a safe and convenient means of using electrically powered equipment within the incubator chamber. The IP66 socket is powered on a completely separate circuit and therefore has its own plug, lead and fuse.

**NOTICE! Risk of material damage**

- ▶ Both the incubator and the IP66 enclosure must be plugged into an electrical supply protected by an RCD device. Any device chosen must be a “self-resetting” type which will automatically reconnect power to the incubator as soon as power is restored after a power failure.
- 

The socket (see Fig. 12-8 on p. 89) is located on the back wall of the chamber, on the right-hand side between the second and third shelf. The socket is powered by an independent power inlet located above the control box at the rear of the incubator (see Fig. 12-7 on p. 87). The socket also has an independent

fuse which is rated at 4 Amps. There is a dedicated switch for this socket, illuminated green when it is on; the switch is located on the left front of the incubator.

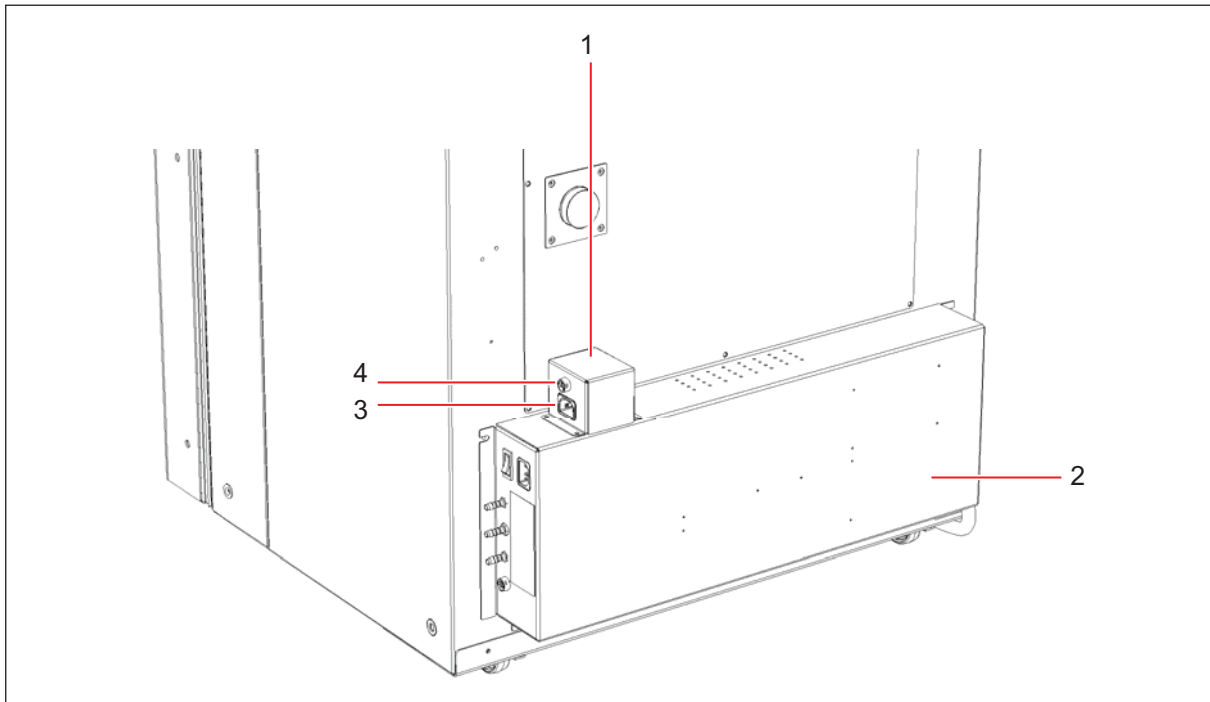

Fig. 12-7: IP66 Enclosure

1 IP66 enclosure

3 IP66 power inlet

2 Control box

4 IP66 fuse holder

## Equipment options

Galaxy® 170 R/170 S CO<sub>2</sub> Incubators

English (EN)



### NOTICE! Risk of material damage

Working with electrical power inside a humid environment (where the incubator is humidified) can cause damage. The following precautions should be observed:

- ▶ The instrument or equipment, and its external connections, to be used inside the chamber should be specified as suitable for use in a humid environment, and at 37 °C (see also “Using Powered Equipment within the Chamber”). If in doubt, consult with the manufacturer of the equipment.
- ▶ Always ensure the connections are properly and securely made.
- ▶ Be sure to switch OFF the green illuminated switch on the front left of the incubator before connecting or disconnecting equipment inside the chamber, if equipped with optional IP66 socket.
- ▶ The Sealing Cap must always be in place when the socket is not in use.
- ▶ Both the incubator and the IP66 enclosure must be plugged into an electrical supply protected by an RCD device. Any device chosen must be a self-resetting type which will automatically reconnect power to the incubator as soon as power is restored following a power failure.



If the incubator is to be used humidified, the normal RH level is ~ 95 %, so any electrically powered equipment or device to be used inside the chamber must be designed for use in a humid atmosphere. Consult the manufacturer of the equipment to ensure that it is suitable.

To minimize the thermal gradient within the chamber, the instrument you place inside the chamber should be placed on the bottom shelf. The heat dissipated by the equipment should be as low as possible to minimize thermal disturbance to the chamber. Some shakers, stirrers etc., have been specifically designed to give a low heat output for use in incubators. The maximum heat that can be dissipated within the chamber is variable, depending on the difference between the ambient and programmed temperatures. If the heat dissipated is too great, the chamber will tend to overheat. If this happens, the control parameters can be adjusted to compensate.



Any heat-generating equipment used inside the chamber will naturally affect the temperature performance of the incubator. For this reason, if you plan to use equipment which may generate heat in the chamber, we recommend equipping the incubator with the optional cooling system (see *Cooling system* on p. 65).

To connect to the socket (see Fig. 12-8 on p. 89) inside the chamber, a power cable with a matching IP66 plug is supplied. This power cable should be fitted by a qualified person to the equipment or device to be used inside the chamber. If the cable cannot be fitted, contact your distributor, giving details of the connectors required, so they can supply a suitable lead.



**NOTICE! Risk of material damage**

- ▶ The Electrical Socket and the matching plug are both sealed to IP66 and are capable of being heated to 120 °C during the High Temperature Disinfection cycle, but the electrical cable is NOT rated for use at 120 °C. Therefore, the equipment or device and the connecting cable must be removed from the chamber, and the Sealing Cap replaced on the socket prior to starting a High Temperature Disinfection cycle.

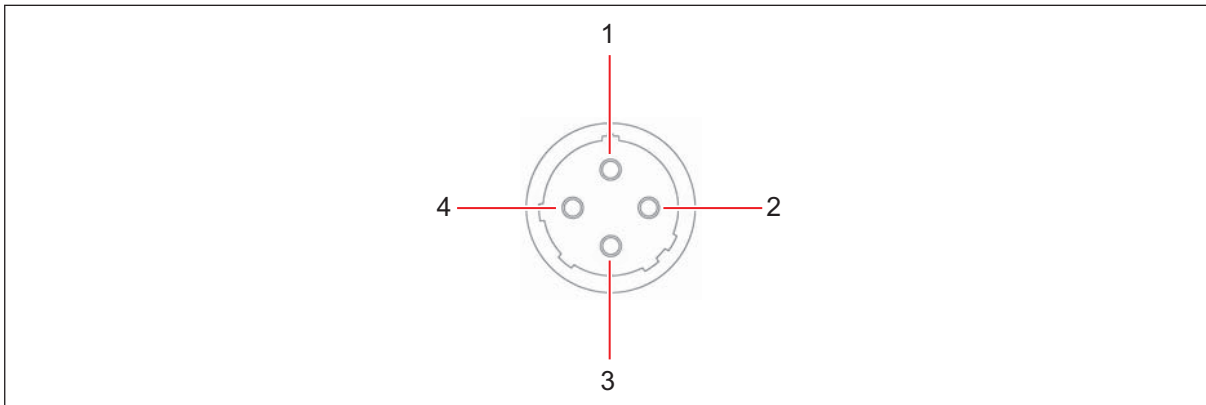

Fig. 12-8: IP66 Socket

**1 Live**

**3 Ground**

**2 Not used**

**4 Neutral**

## 12.9 Humidity alert and monitoring package (Galaxy R only)

The humidity alert package includes a humidity tray warning system and humidity display and alarm function, both providing optimal feedback on relative humidity inside the incubator chamber.

### 12.9.1 Humidity tray warning system

The humidity tray warning system is designed to prevent the water level in the humidity reservoir from becoming too low. The water level is continuously measured by an optical water level sensor. If the water level in the humidity tray become too low a "Humidity Water Low Alarm" is displayed. This alarm can be cancelled by pressing any key, but it will re-activate when the glass door is opened and closed.

The humidity alarm system can be deactivated as follows:



Humidity Tray Warning System with High Temperature Decontamination Option (Galaxy R model only).

**Equipment options**Galaxy® 170 R/170 S CO<sub>2</sub> Incubators

English (EN)

**NOTICE! Risk of damage to equipment**

The bottom surface of the incubator is heated to over 150 °C during the decontamination cycle which may affect the sensor or the cable if left in contact with the bottom of the incubator.

- ▶ Never leave the humidity warning sensor on the bottom surface of the incubator during a high temperature decontamination cycle. Place it on the shelf above the humidity tray and ensure that the cable is not resting on the base of the incubator chamber.

1. Press *USER*.
2. Select *DISABLE* and toggle *HUMIDITY WARNING* from *ON* to *OFF* using the ◀▶ keys.
3. Press *ENTER*.
4. Refill the humidity tray with 1.5 liters of warm (~37.0 °C) distilled water.

When the water level has been replenished and the door is closed the system will re-arm.

### 12.9.2 Humidity display and alarm system

The Humidity Display and Alarm System is designed to measure the relative humidity level (rH) in the chamber and to display the chamber rH on the display screen. Under normal operating conditions and using the supplied humidity tray, the rH level will reach a maximum of 95 - 96 % after being left overnight. The Humidity Sensor will activate an alarm if relative humidity falls below the preset limit of 88 %. The sensor is located on the rear wall of the chamber, below the CO<sub>2</sub> Sensor. The Humidity Display is always active, but the Alarm System can be deactivated as follows:

1. Press *USER*.
2. Select *DISABLE*, and toggle *RELATIVE HUMIDITY* from *ON* to *OFF* using the ◀▶ keys.
3. Press *ENTER*.

The Alarm System is disarmed for 1 hour or when it achieves 88% R/H, when the incubator is switched on, or if the door is opened and closed.

An Alarm is signaled by a flashing *RH LOW ALARM* message. If the humidity level rises above 88 % during the 1 hour time out period, the Humidity Alarm System will be armed. The Alarm will then be triggered when the R/H level falls below 88 % and will be recorded by the Alarm Log. The Alarm can be acknowledged by pressing any key. No further Alarms will occur unless the door is opened and closed, or power to the incubator is removed then restored.



The Humidity Sensor is protected by a white porous plastic cover, care must be taken not to spill any liquid into the sensor. The white porous cover should be protected with the black plastic sleeve provided when cleaning the incubator. The white porous cover can be removed and autoclaved but care should be taken not to touch or wet the sensor when the cover is removed.

## 12.10 Copper inner chamber

Copper naturally changes color. This incubator had a bright finish when it was manufactured. The dull finish that you see is a result of oxidation of the copper surface: it is the properties of this oxidation that create the important anti-microbial surface.

**Equipment options**

Galaxy® 170 R/170 S CO<sub>2</sub> Incubators  
English (EN)



## 13 Stacking stand installation

### 13.1 Intended use

The stacking stand is designed for two Galaxy 170 incubators to be stacked on top of each other. The stand can also be used to stack two Galaxy Plus series (not available in North America) incubators or any combination of a Galaxy Plus model with a Galaxy 170. For optimum stability, if a 170 incubator is being stacked with another Galaxy model, the 170 should be on the bottom.

### 13.2 Warnings for intended use

Before using the stacking stand, read this entire section and observe the following general safety instructions.



**WARNING! Personnel injury and equipment damage!**

- ▶ Great care should be taken when moving the stacked incubators. Hazards, including uneven surfaces and obstructions, may cause the stacked assembly to topple, potentially injuring personnel.



**CAUTION! Personnel injury and equipment damage!**

- ▶ Four people are required to safely lift a Galaxy 170 incubator.
  - ▶ When lifting, be sure to use the lifting handles provided with the incubator.
  - ▶ NEVER lift the incubator by the door as this may cause damage.
- 

### 13.3 General description

The stacking stand is designed for two Galaxy 170 incubators to be stacked on top of each other. The stand can also be used to stack two Galaxy Plus series (not available in North America) incubators or any combination of a Galaxy Plus model with a Galaxy 170. For optimum stability, if a 170 incubator is being stacked with another Galaxy model, the 170 should be on the bottom. There is a lower and upper stacking frame kit available.

#### 13.3.1 Ordering options

The following Table lists the options available for the stacking stand when ordering. Contact Eppendorf sales for ordering information.

---

Description
Lower and Upper Stacking Frame Kit
Upper Stacking Frame only
Lower Stacking Frame only

---

## Stacking stand installation

Galaxy® 170 R/170 S CO<sub>2</sub> Incubators  
English (EN)

---

Kit for Stacking a pre-2000 incubator onto a Galaxy 170

---

### 13.3.2 Stacking frame kit contents

All of the parts listed for both kits below are included in the Lower and Upper Stacking Frame Kit (P0628-6270). Check that you have received all of the parts appropriate to the kit you ordered:

**Upper Stacking Frame contents:** See the Table below.

Quantity	Part Description
1	Upper stacking plate with foam insulation
4	M6 x 50 mm slotted pan head bolts
4	Foot locking brackets
4	M6 x 12 mm cap head Allen bolts
1	Allen wrench set
2	Incubator feet with M8 nuts
4	Pads for incubator feet

**Lower Stacking Frame contents:** See the Table below.

Quantity	Part Description
1	Lower stacking frame
2	Swivel castors, each with adjustable stabilizing foot
2	Fixed castors
8	M8 x 20 mm button head bolts with washers (to mount fixed castors)
2	Incubator feet with M8 nuts
4	Pads for incubator feet
1	Wrench to attach castors
1	Allen wrench set

## 13.4 Instructions for stacking incubators



### **WARNING! Personnel injury and equipment damage!**

- ▶ Great care should be taken when moving the stacked incubators. Hazards, including uneven surfaces and obstructions, may cause the stacked assembly to topple, potentially injuring personnel.



**CAUTION! Personnel injury and equipment damage!**

- ▶ Four people are required to safely lift a Galaxy 170 incubator.
- ▶ When lifting, be sure to use the lifting handles provided with the incubator.
- ▶ NEVER lift the incubator by the door as this may cause damage.

1. At least two persons are needed to very carefully tip the first incubator forward on its front feet, until the rear castors are accessible. Hold the incubator steady.



**CAUTION! Equipment Damage!**

- ▶ The illustration below is for reference only. Never turn the incubator upside down.



A third person should be used to remove the rear castors in the next step.

2. Utilizing a third person and using a flat-bladed screwdriver, remove the rear castors from the bottom of the incubator.

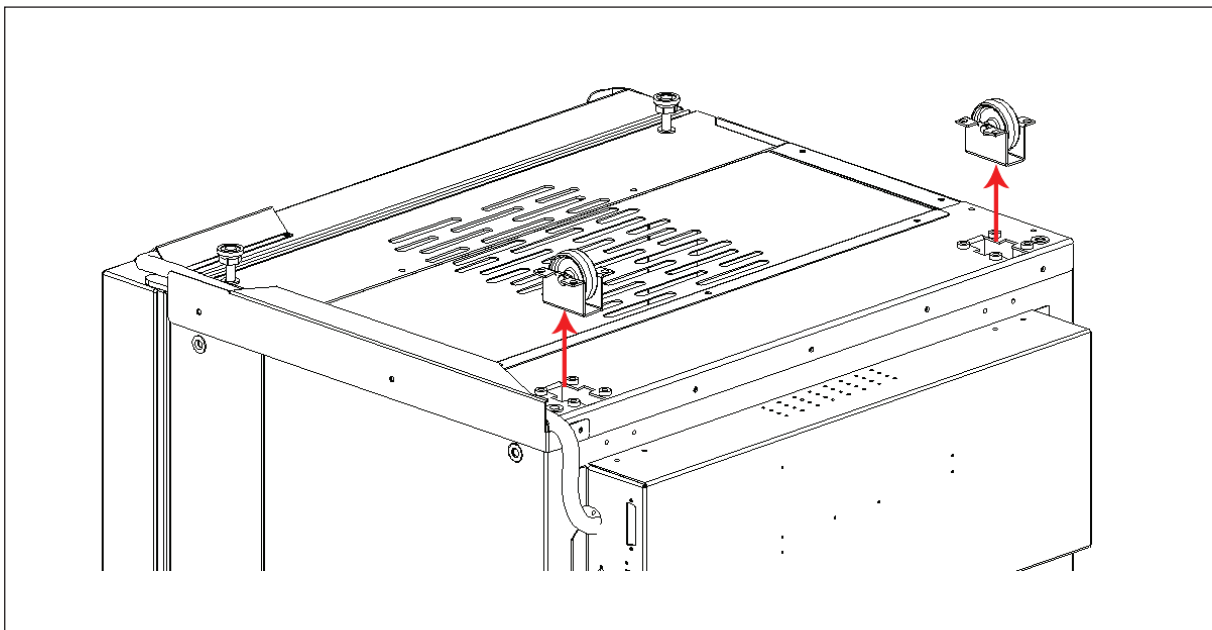

Fig. 13-1: Castor Removal

3. In place of the castors, fit the feet to the rear of the incubator (see the Figure below).

**Stacking stand installation**

Galaxy® 170 R/170 S CO<sub>2</sub> Incubators  
English (EN)

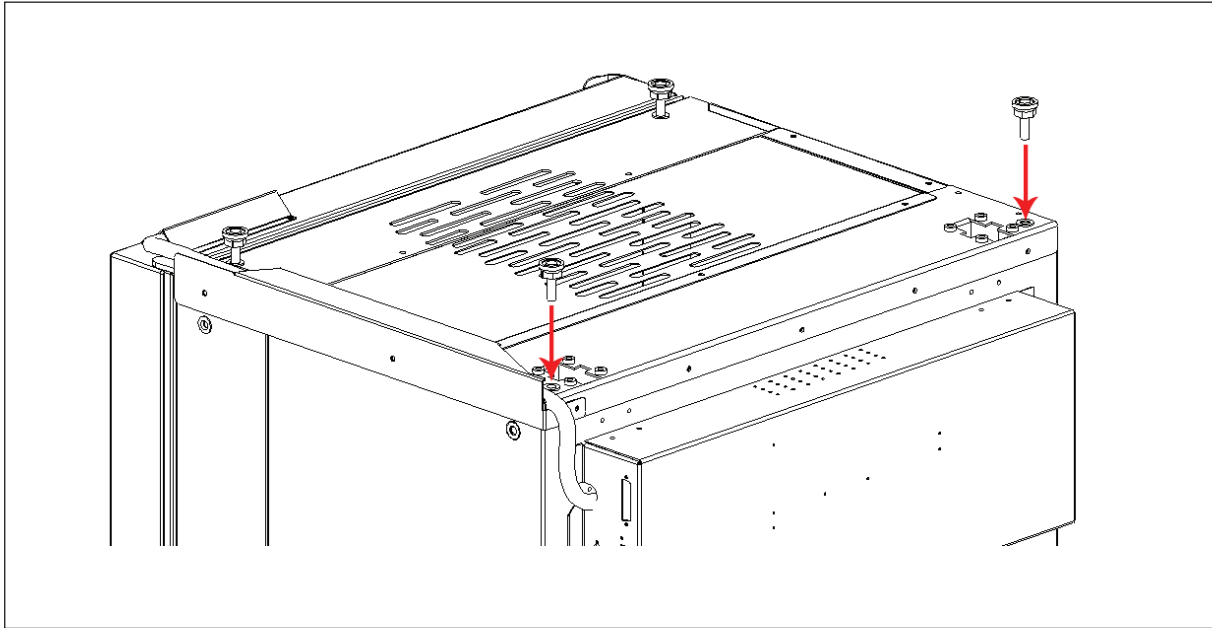

Fig. 13-2: Feet Installation

4. Adjust the height of the feet to ensure that the incubator is level.



The feet on the bottom incubator should ideally be set at a height of 32mm, and the feet on the top incubator at 32mm.

5. Repeat steps 1-4 for the second incubator.
6. Using the wrench provided, fit the adjustable castors to the front underside of the lower stacking frame (see Figure below).

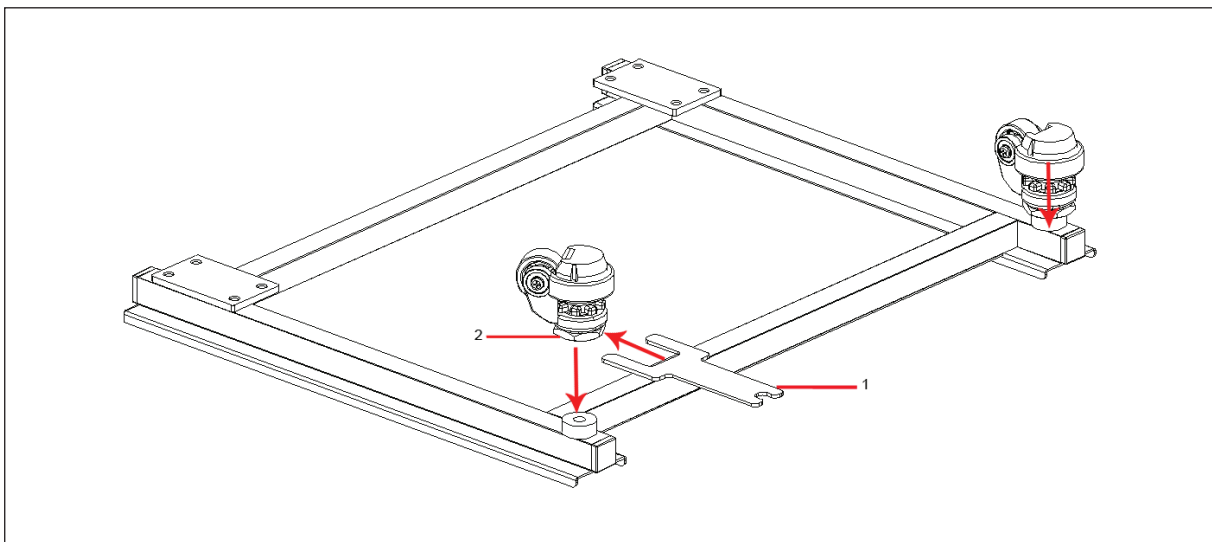

Fig. 13-3: Lower Stacking Frame Castor Installation

1 Wrench

2 Castor

7. Using the appropriate Allen wrench in the set provided, install the fixed castors to the rear underside of the lower stacking frame using the M8 button head bolts (see Figure below).

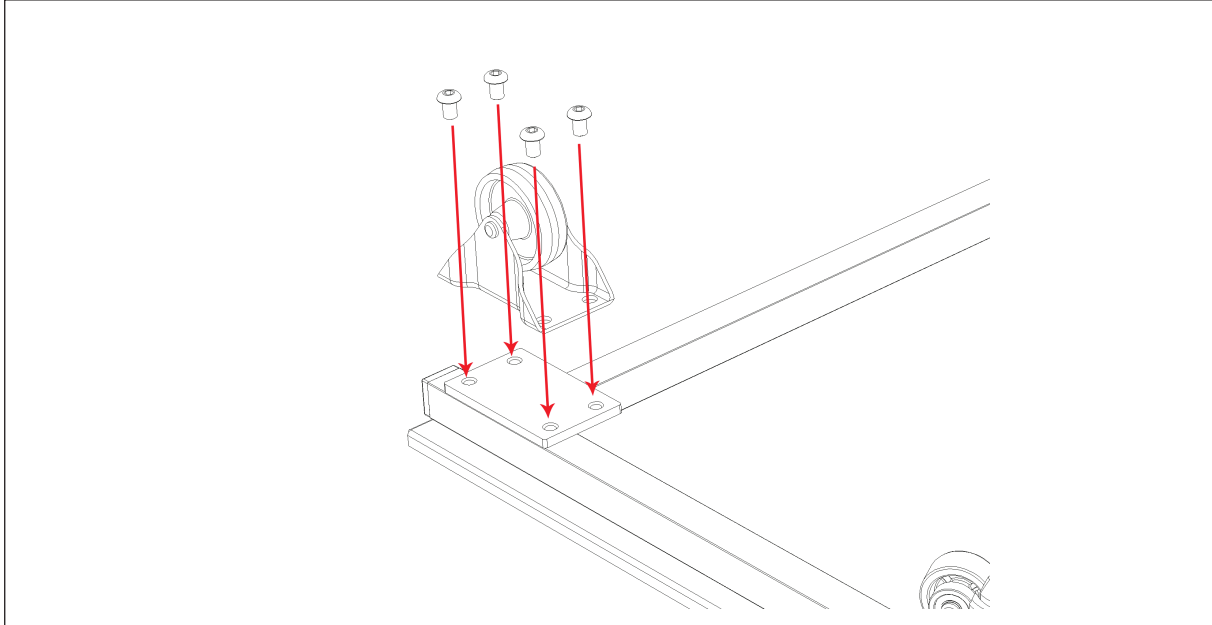

Fig. 13-4: Castor Bolts

8. Turn the lower stacking frame over, ensuring that it is on a flat surface.

**Stacking stand installation**

Galaxy® 170 R/170 S CO<sub>2</sub> Incubators  
English (EN)

9. With four people, each using one of the lifting handles, lift the bottom incubator onto the stand, placing the incubator feet into the stand's guiderails (see Figure below).

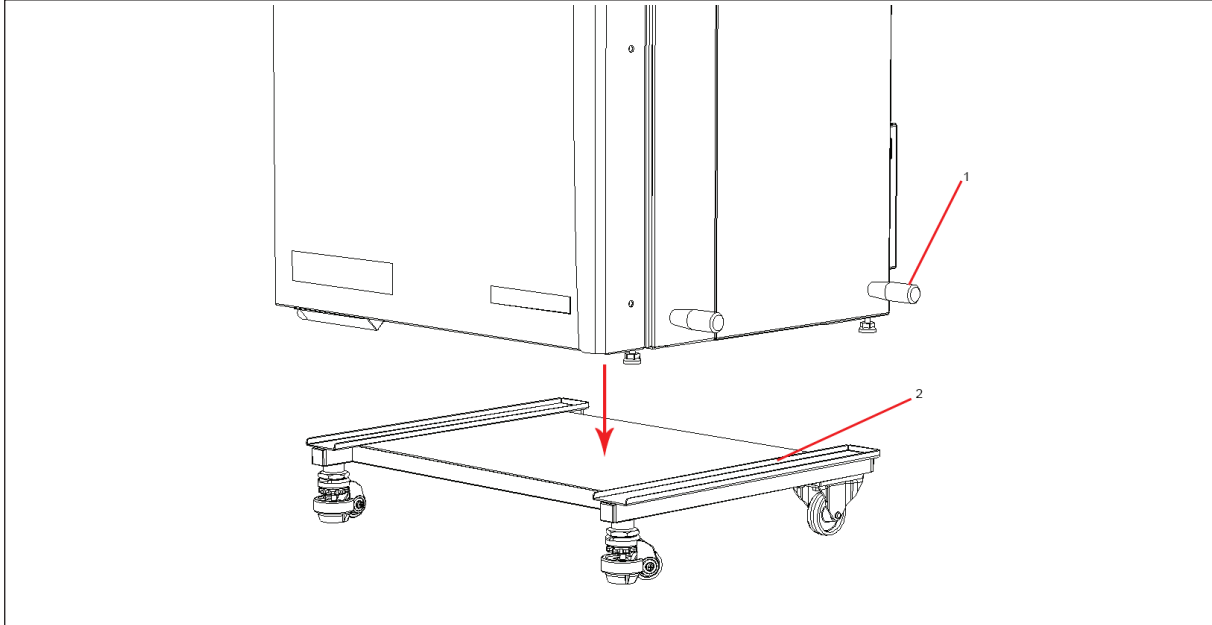

Fig. 13-5: Lifting Handles And Guides For Incubator Feet

**1 Incubator Lifting Handles****2 Guides For Incubator Feet**

10. Using a flat-bladed screwdriver, adjust the front castors until their rubber feet contact the floor (see Figure below).

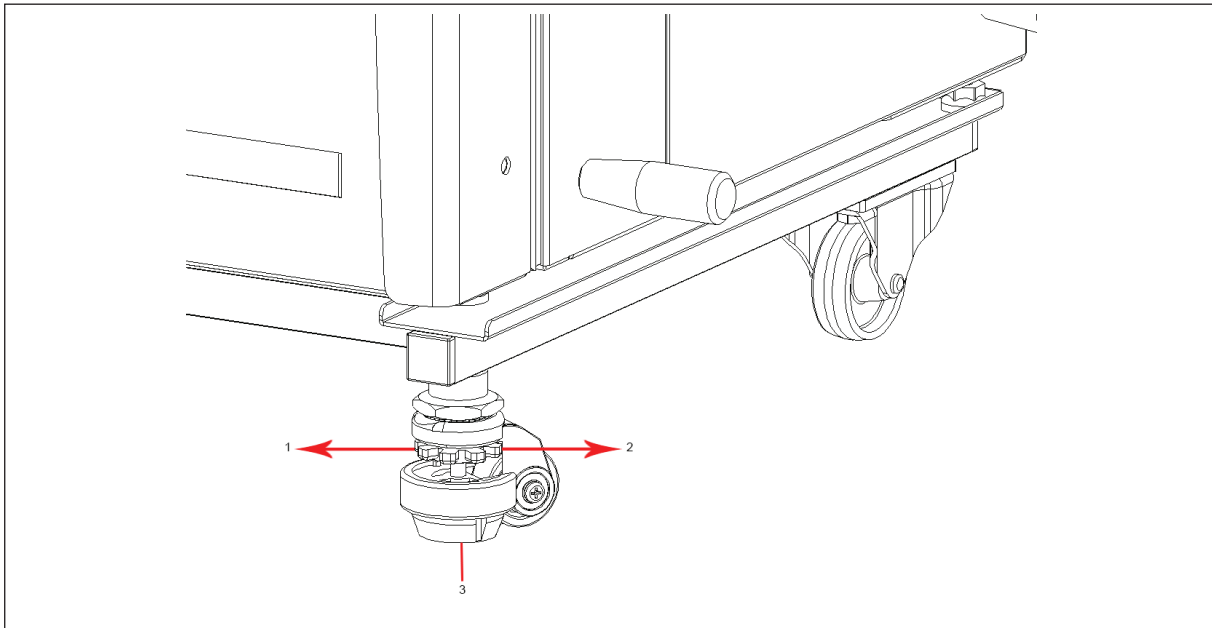

Fig. 13-6: Leveling Foot Adjustment

- 1 Turn red adjuster in this direction to move foot 3 Rubber Leveling Foot up.**
- 2 Turn red adjuster in this direction to move foot down.**

11. Remove the thread covers from the top of the incubator (in the locations shown below), then, using a flat-bladed screwdriver, attach the upper stacking frame to the top of the bottom incubator using the M6 x 50mm bolts provided.

**Stacking stand installation**

Galaxy® 170 R/170 S CO<sub>2</sub> Incubators  
English (EN)

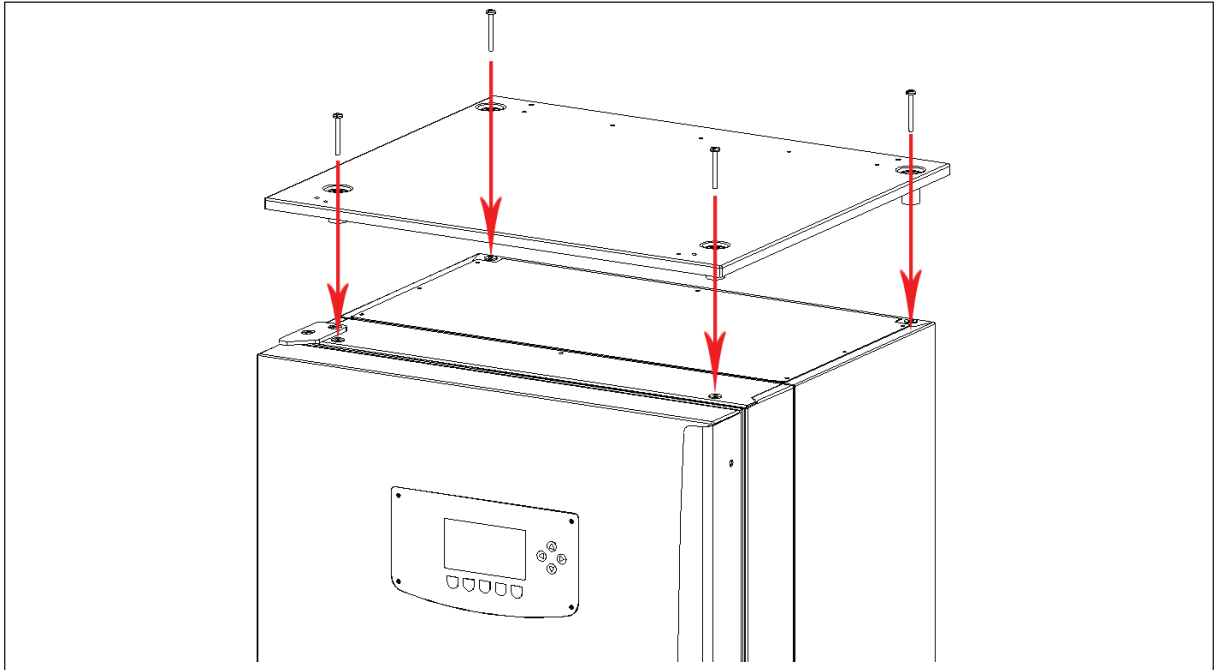

Fig. 13-7: Upper Stacking Frame Installation

12. With four people, each using one of the lifting handles, lift the top incubator onto the upper stacking frame, making sure to place a pad under each foot. Fit the incubator feet into the dimples on the upper stacking frame (see Figure below).

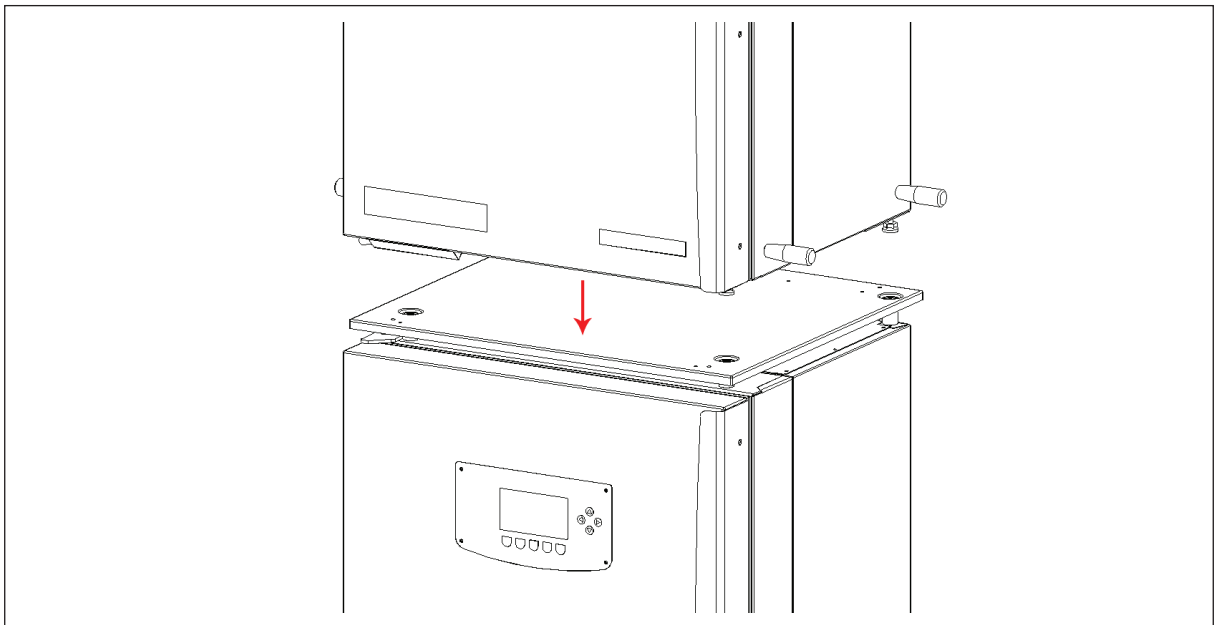

Fig. 13-8: Incubator Into The Upper Stacking Frame



13. Secure the top incubator by fitting the foot-clamping brackets to its feet. As shown below, with the door open for easy access, install both front brackets using the Allen key set and the M6 socket head bolts provided.

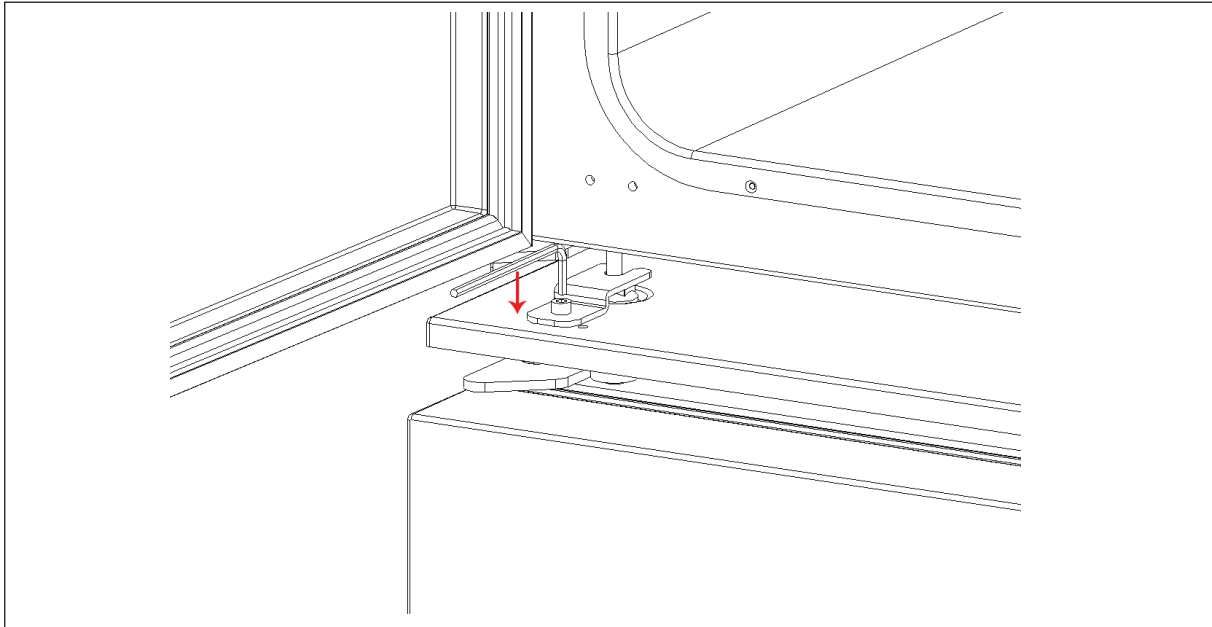

Fig. 13-9: Front Bracket Installation

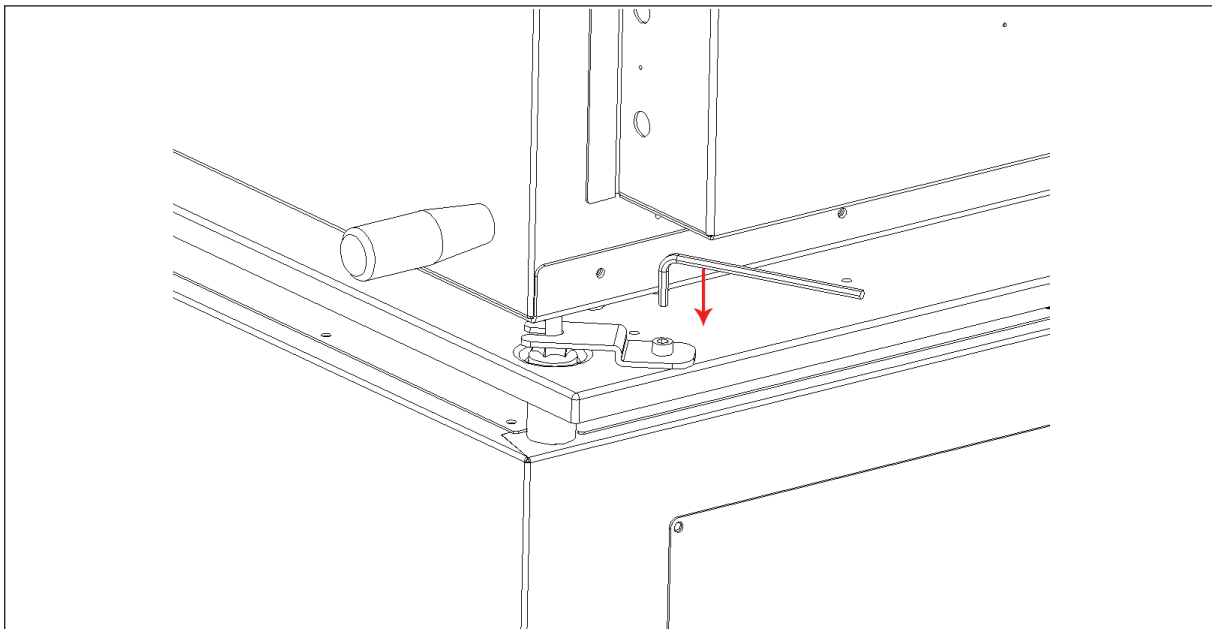

Fig. 13-10: Allen Wrench And Bracket

14. In the same way, install the other two brackets at the rear of the incubator.

### Stacking stand installation

Galaxy® 170 R/170 S CO<sub>2</sub> Incubators  
English (EN)

## 13.5 Instructions for stacking a different model CO<sub>2</sub> incubator onto a Galaxy 170



### WARNING! Personnel injury and equipment damage!

- ▶ Great care should be taken when moving the stacked incubators. Hazards, including uneven surfaces and obstructions, may cause the stacked assembly to topple, potentially injuring personnel.



### CAUTION! Personnel injury and equipment damage!

- ▶ Four people are required to safely lift a Galaxy 170 incubator.
- ▶ When lifting, be sure to use the lifting handles provided with the incubator.
- ▶ NEVER lift the incubator by the door as this may cause damage.

This option can be ordered (P0628-7770) in addition to the upper stacking frame to allow any pre-2000 Galaxy, Innova or Excella incubator to be stacked on top of a Galaxy 170 (or Galaxy Plus) incubator. The upper stacking frame comes fitted with two extra channels to accommodate the feet positions of the older incubators; one strengthening channel on the underside of the plate adds rigidity.

1. Remove the two front bolts securing the channel section and loosen the two back bolts (see Figure below). Retain the two front bolts for use in step 2.

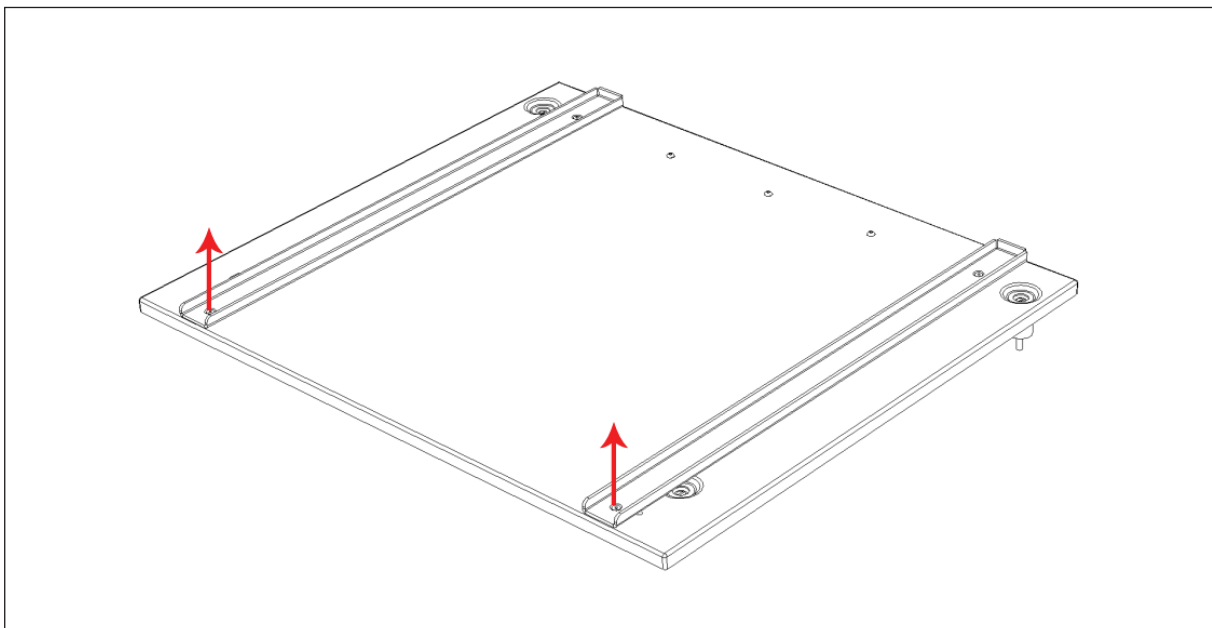

Fig. 13-11: Channel Section Bolts

2. Rotate the channel sections as shown below to allow the plate to be attached to the bottom incubator. Once the plate is fitted, fix the channel sections back into position using the bolts removed in step 1. Easier access can be gained by opening the incubator door. Ensure that all nuts and washers are replaced and that all bolts are tightened securely.

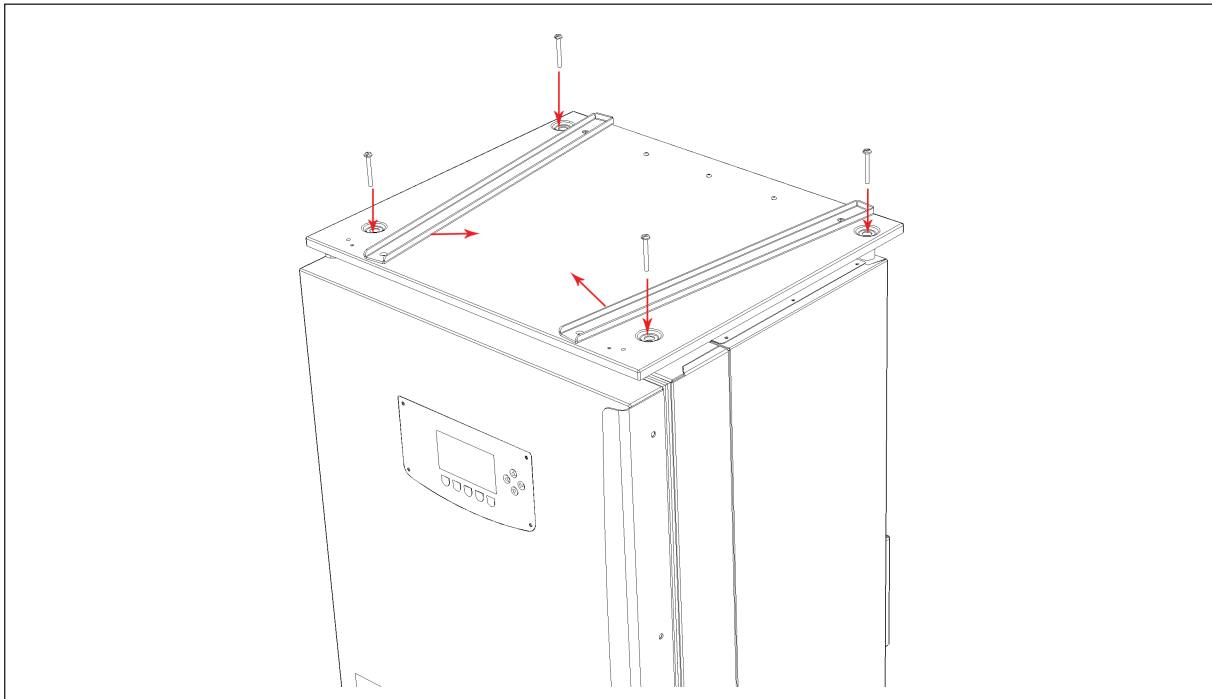

Fig. 13-12: Rotated Channel Sections

3. The top incubator can now be lifted onto the plate, locating the incubator's feet within the channel sections.

**Stacking stand installation**

Galaxy® 170 R/170 S CO<sub>2</sub> Incubators  
English (EN)

- 14 Declaration of conformity
- 14.1 Declaration of conformity for 170 R



# Declaration of Conformity

The product named below fulfills the requirements of directives and standards listed. In the case of unauthorized modifications to the product or an unintended use this declaration becomes invalid.

**Product name:**

Galaxy® 170 R  
including accessories

**Product type:**

CO<sub>2</sub> Incubator

**Relevant directives / standards:**

2006/95/EC: EN 61010-1, EN 61010-2-010

2004/108/EC: EN 61326-1

Management Board

Portfolio Management

Date: September 04, 2013

Your local distributor: [www.eppendorf.com/contact](http://www.eppendorf.com/contact)  
Eppendorf AG · 22331 Hamburg · Germany  
[eppendorf@eppendorf.com](mailto:eppendorf@eppendorf.com)

Eppendorf and the Eppendorf Logo are registered trademarks of Eppendorf AG Hamburg/Germany. All rights reserved. Incl. graphics and pictures. Copyright 2013 © by Eppendorf AG.

ISO 9001  
Certified

ISO 13485  
Certified

ISO 14001  
Certified

6710 900.157-00

**Declaration of conformity**

Galaxy® 170 R/170 S CO<sub>2</sub> Incubators  
English (EN)

## 14.2 Declaration of conformity for 170 S

**eppendorf****Declaration of Conformity**

The product named below fulfills the requirements of directives and standards listed. In the case of unauthorized modifications to the product or an unintended use this declaration becomes invalid.

**Product name:**

Galaxy® 170 S  
including accessories

**Product type:**

CO<sub>2</sub> Incubator

**Relevant directives / standards:**

2006/95/EC: EN 61010-1, EN 61010-2-010

2004/108/EC: EN 61326-1



Management Board



Portfolio Management

Date: September 04, 2013

Your local distributor: [www.eppendorf.com/contact](http://www.eppendorf.com/contact)  
Eppendorf AG · 22331 Hamburg · Germany  
[eppendorf@eppendorf.com](mailto:eppendorf@eppendorf.com)

Eppendorf and the Eppendorf Logo are registered trademarks of Eppendorf AG Hamburg/Germany. All rights reserved incl. graphics and pictures. Copyright 2013 © by Eppendorf AG.

ISO 9001  
Certified

ISO 13485  
Certified

ISO 14001  
Certified

6710 900 050-00

[www.eppendorf.com](http://www.eppendorf.com)

**Index**

**A**

access code, programming .....32  
 Alarm arming delay .....46  
 Alarm duration .....45  
 Alarm events.....36  
 Ambient conditions .....60  
 ATEX Guideline .....17

**B**

BMS relay contact alarm .....66

**C**

Caution, explanation of .....7  
 Chamber alarm system.....46  
 Chamber alarm system function .....40  
 Chamber alarms .....39  
 CO<sub>2</sub> Auto-zero system .....47  
 Control system.....13  
 Controlled humidity tray .....13  
 Cooling system .....65  
 Copper inner chamber .....91  
 Copyright.....2

**D**

Daily checks .....51  
 Danger, explanation of .....7  
 Datalogger .....36  
 Direct heating system.....13  
 Disinfection .....35  
 Disposal .....57  
 Door open alarm.....45

**E**

Enabling or disabling O<sub>2</sub> control ..... 81

**F**

Fuse replacement..... 53

**H**

Hazard symbols ..... 7  
 High temperature disinfection..... 55, 68  
 High temperature disinfection with O<sub>2</sub> control .... 71  
 Humidity tray ..... 30

**I**

Inspection of boxes..... 12  
 IP66..... 86

**M**

Manual conventions..... 8  
 Monthly check ..... 51  
 Multiple options..... 14

**N**

Notice, explanation of..... 7

**O**

O<sub>2</sub> control (0.1 - 19 %)..... 80  
 O<sub>2</sub> control (1 - 19 %)..... 72  
 O<sub>2</sub> control (1 - 95 %)..... 83  
 Over-temperature cut-out and alarm ..... 47

**P**

Packing list verification..... 13  
 Power frequency ..... 35  
 Product liability..... 18  
 Programming desired O<sub>2</sub> level ..... 82  
 Programming the alarm..... 44

**Index**

Galaxy® 170 R/170 S CO<sub>2</sub> Incubators  
English (EN)

**R**

Referencing to atmosphere .....	74
Removing access code .....	32
Removing and replacing O <sub>2</sub> sensor .....	76
Replace sensor now.....	75
Replace sensor soon.....	75
Replacing filter disc.....	77
Replacing the fuse .....	53
Requirements, utilities .....	21
Routine checks of CO <sub>2</sub> control option (170 R only) .....	52
Routine maintenance.....	51

**S**

Seamless chamber.....	14
Setting date and time .....	34
Setting temperature and CO <sub>2</sub> .....	44
Setting the CO <sub>2</sub> high and low alarms.....	45
Setting the high and low temperature alarms.....	44
Setting up N <sub>2</sub> tank .....	72, 80, 83
Setting up O <sub>2</sub> control .....	84
Setting up oxygen control .....	72
Stacking devices.....	14
Stacking incubators.....	94
Stacking stand intended use .....	93
Standard features .....	14
Symbols used .....	8

**T**

Temperature sensor system alarms.....	47
Trademarks.....	2
Troubleshooting the O <sub>2</sub> sensor .....	78
Two-level alarm system.....	14

**U**

Unpacking boxes .....	13
User requirement.....	17
User settings.....	33
Using this manual .....	7
Utilities requirements .....	21

**W**

Warning, explanation of .....	7
Weekly checks .....	51
Working with cell culture.....	30
Working with sensitive material .....	30





# Evaluate your manual

Give us your feedback.  
[www.eppendorf.com/manualfeedback](http://www.eppendorf.com/manualfeedback)